

## Chapter 3

**3-1**

$$\begin{aligned}\Sigma M_o &= 0 \\ 18R_B - 6(100) &= 0 \\ R_B &= 33.3 \text{ lbf} \quad \text{Ans.}\end{aligned}$$

$$\begin{aligned}\Sigma F_y &= 0 \\ R_o + R_B - 100 &= 0 \\ R_o &= 66.7 \text{ lbf} \quad \text{Ans.} \\ R_C = R_B &= 33.3 \text{ lbf} \quad \text{Ans.}\end{aligned}$$

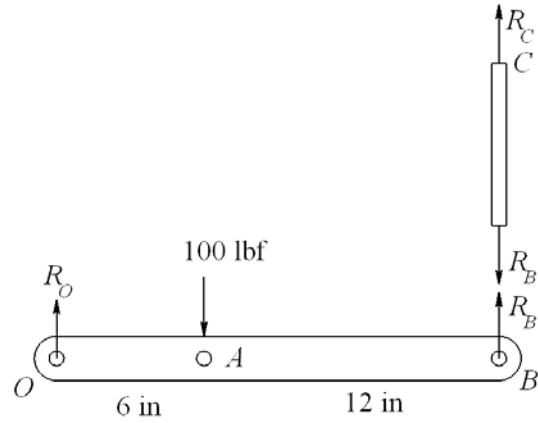

**3-2**

Body *AB*:

$$\begin{aligned}\Sigma F_x &= 0 & R_{Ax} &= R_{Bx} \\ \Sigma F_y &= 0 & R_{Ay} &= R_{By} \\ \Sigma M_B &= 0 & R_{Ay}(10) - R_{Ax}(10) &= 0 \\ R_{Ax} &= R_{Ay}\end{aligned}$$

Body *OAC*:

$$\begin{aligned}\Sigma M_o &= 0 & R_{Ay}(10) - 100(30) &= 0 \\ R_{Ay} &= 300 \text{ lbf} \quad \text{Ans.}\end{aligned}$$

$$\Sigma F_x = 0 \quad R_{Ox} = -R_{Ax} = -300 \text{ lbf} \quad \text{Ans.}$$

$$\Sigma F_y = 0 \quad R_{Oy} + R_{Ay} - 100 = 0$$

$$R_{Oy} = -200 \text{ lbf} \quad \text{Ans.}$$

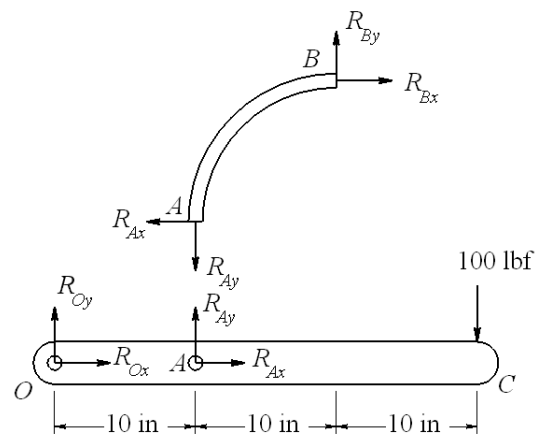

3-3

$$R_O = \frac{0.8}{\tan 30^\circ} = 1.39 \text{ kN} \quad \text{Ans.}$$

$$R_A = \frac{0.8}{\sin 30^\circ} = 1.6 \text{ kN} \quad \text{Ans.}$$

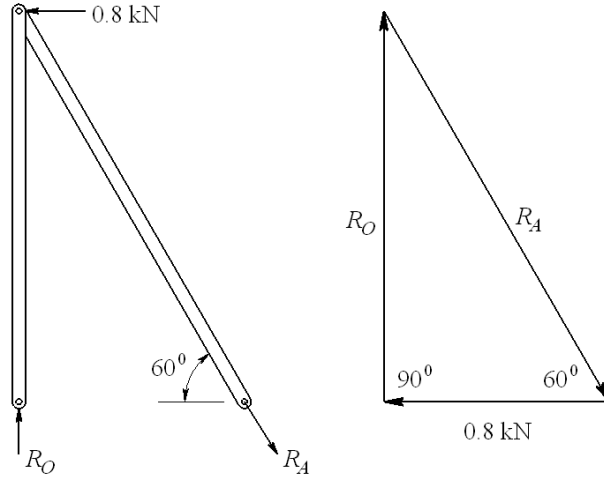

3-4

Step 1: Find  $R_A$  &  $R_E$

$$h = \frac{4.5}{\tan 30^\circ} = 7.794 \text{ m}$$

$$\Sigma M_A = 0$$

$$9R_E - 7.794(400 \cos 30^\circ) - 4.5(400 \sin 30^\circ) = 0$$

$$R_E = 400 \text{ N} \quad \text{Ans.}$$

$$\Sigma F_x = 0 \quad R_{Ax} + 400 \cos 30^\circ = 0$$

$$R_{Ax} = -346.4 \text{ N}$$

$$\Sigma F_y = 0 \quad R_{Ay} + 400 - 400 \sin 30^\circ = 0$$

$$R_{Ay} = -200 \text{ N}$$

$$R_A = \sqrt{346.4^2 + 200^2} = 400 \text{ N} \quad \text{Ans.}$$

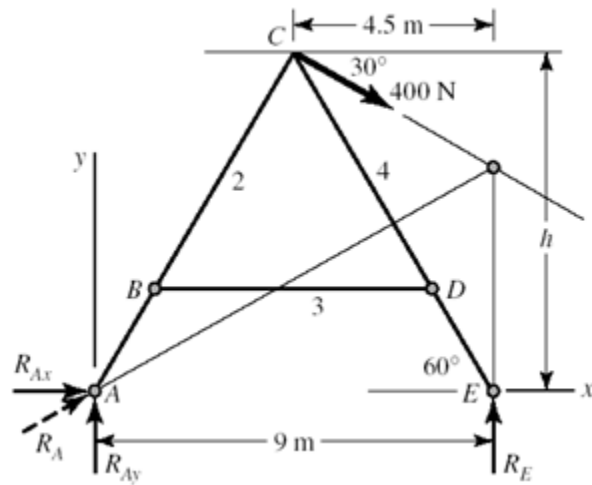

Step 2: Find components of  $R_C$  on link 4 and  $R_D$

$$\Sigma M_C = 0$$

$$400(4.5) - (7.794 - 1.9)R_D = 0$$

$$R_D = 305.4 \text{ N} \quad \text{Ans.}$$

$$\Sigma F_x = 0 \Rightarrow (R_{Cx})_4 = 305.4 \text{ N}$$

$$\Sigma F_y = 0 \Rightarrow (R_{Cy})_4 = -400 \text{ N}$$

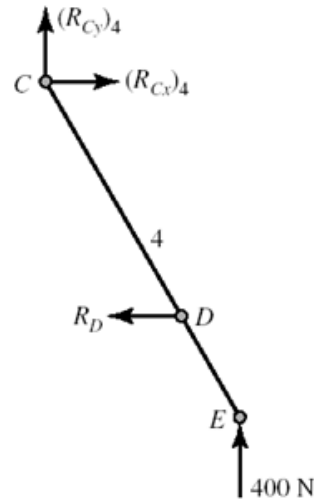

Step 3: Find components of  $R_C$  on link 2

$$\sum F_x = 0$$

$$(R_{Cx})_2 + 305.4 - 346.4 = 0$$

$$(R_{Cx})_2 = 41 \text{ N}$$

$$\sum F_y = 0$$

$$(R_{Cy})_2 = 200 \text{ N}$$

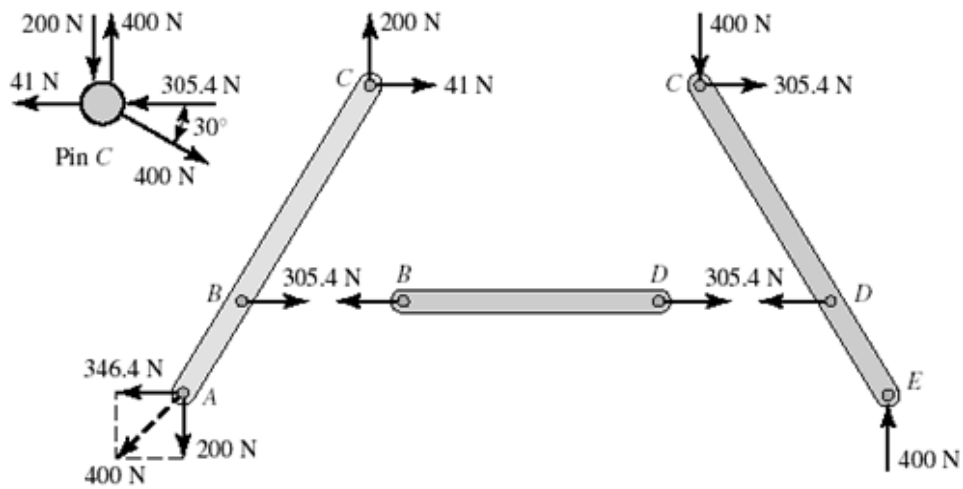
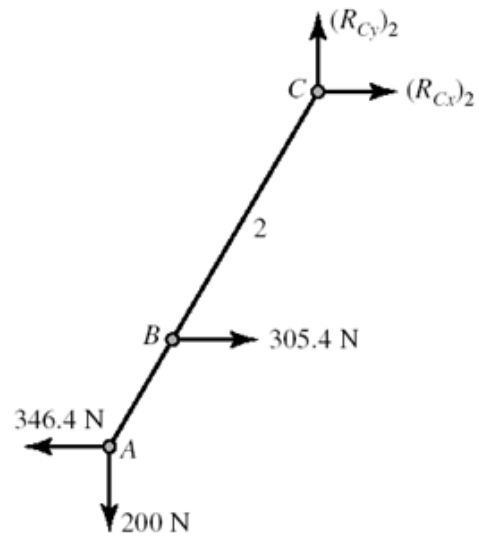

**3-5**

$$\begin{aligned} \Sigma M_C &= 0 \\ -1500R_1 + 300(5) + 1200(9) &= 0 \\ R_1 &= 8.2 \text{ kN} \quad \text{Ans.} \\ \Sigma F_y &= 0 \\ 8.2 - 9 - 5 + R_2 &= 0 \quad R_2 = 5.8 \text{ kN} \quad \text{Ans.} \end{aligned}$$

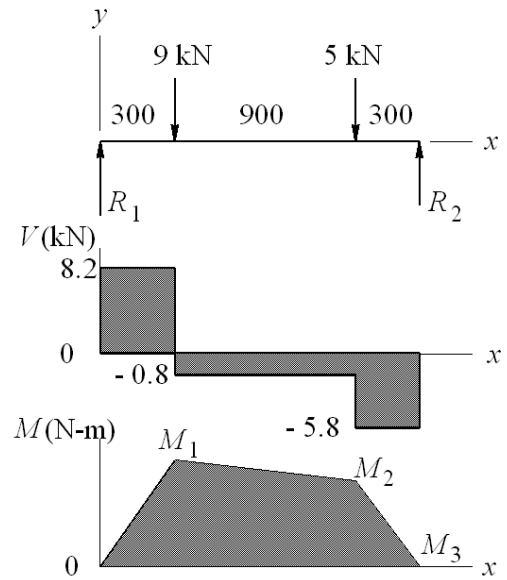

$$\begin{aligned} M_1 &= 8.2(300) = 2460 \text{ N}\cdot\text{m} \quad \text{Ans.} \\ M_2 &= 2460 - 0.8(900) = 1740 \text{ N}\cdot\text{m} \quad \text{Ans.} \\ M_3 &= 1740 - 5.8(300) = 0 \quad \text{checks!} \end{aligned}$$

**3-6**

$$\begin{aligned} \Sigma F_y &= 0 \\ R_0 &= 500 + 40(6) = 740 \text{ lbf} \quad \text{Ans.} \\ \Sigma M_0 &= 0 \\ M_0 &= 500(8) + 40(6)(17) = 8080 \text{ lbf}\cdot\text{in} \quad \text{Ans.} \\ M_1 &= -8080 + 740(8) = -2160 \text{ lbf}\cdot\text{in} \quad \text{Ans.} \\ M_2 &= -2160 + 240(6) = -720 \text{ lbf}\cdot\text{in} \quad \text{Ans.} \\ M_3 &= -720 + \frac{1}{2}(240)(6) = 0 \quad \text{checks!} \end{aligned}$$

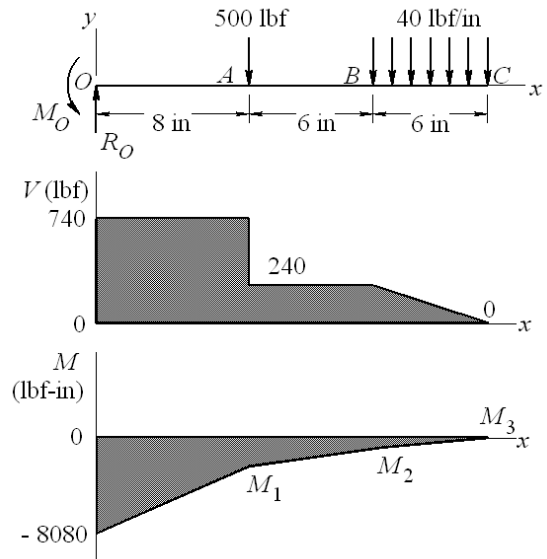

3-7

$$\begin{aligned} \Sigma M_B &= 0 \\ -2.2R_1 + 1(2) - 1(4) &= 0 \\ R_1 &= -0.91 \text{ kN} \quad \text{Ans.} \\ \Sigma F_y &= 0 \\ -0.91 - 2 + R_2 - 4 &= 0 \\ R_2 &= 6.91 \text{ kN} \quad \text{Ans.} \end{aligned}$$

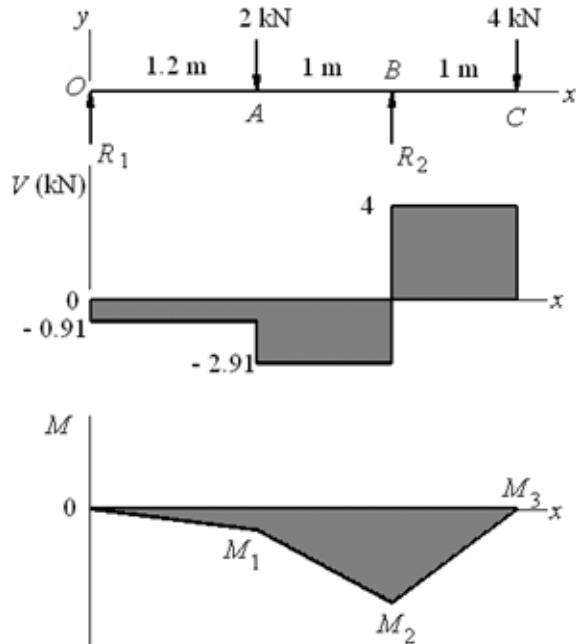

$$M_1 = -0.91(1.2) = -1.09 \text{ kN} \cdot \text{m} \quad \text{Ans.}$$

$$M_2 = -1.09 - 2.91(1) = -4 \text{ kN} \cdot \text{m} \quad \text{Ans.}$$

$$M_3 = -4 + 4(1) = 0 \quad \text{checks!}$$

3-8

Break at the hinge at B

Beam OB:

From symmetry,  
 $R_1 = V_B = 200 \text{ lbf} \quad \text{Ans.}$

Beam BD:

$$\begin{aligned} \Sigma M_D &= 0 \\ 200(12) - R_2(10) + 40(10)(5) &= 0 \\ R_2 &= 440 \text{ lbf} \quad \text{Ans.} \end{aligned}$$

$$\Sigma F_y = 0$$

$$\begin{aligned} -200 + 440 - 40(10) + R_3 &= 0 \\ R_3 &= 160 \text{ lbf} \quad \text{Ans.} \end{aligned}$$

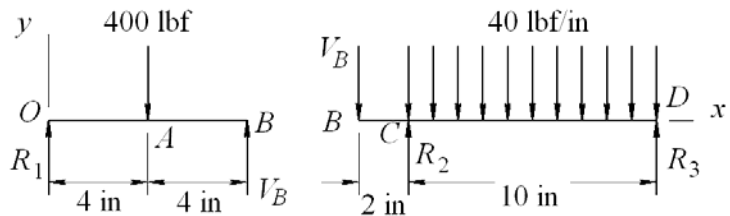

$$M_1 = 200(4) = 800 \text{ lbf} \cdot \text{in} \quad \text{Ans.}$$

$$M_2 = 800 - 200(4) = 0 \quad \text{checks at hinge}$$

$$M_3 = 800 - 200(6) = -400 \text{ lbf} \cdot \text{in} \quad \text{Ans.}$$

$$M_4 = -400 + \frac{1}{2}(240)(6) = 320 \text{ lbf} \cdot \text{in} \quad \text{Ans.}$$

$$M_5 = 320 - \frac{1}{2}(160)(4) = 0 \quad \text{checks!}$$

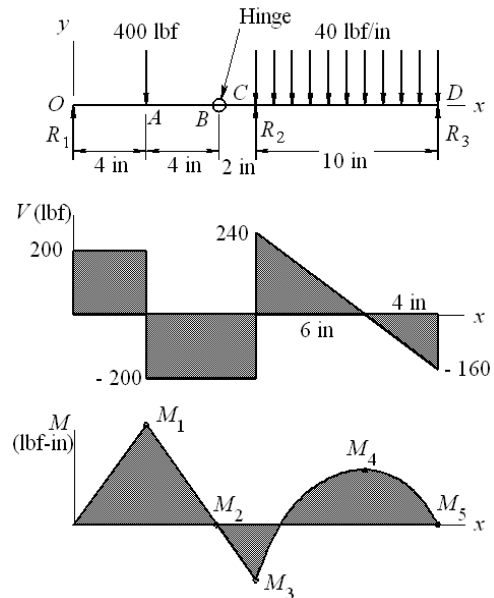

### 3-9

$$q = R_1 \langle x \rangle^{-1} - 9 \langle x - 300 \rangle^{-1} - 5 \langle x - 1200 \rangle^{-1} + R_2 \langle x - 1500 \rangle^{-1}$$

$$V = R_1 - 9 \langle x - 300 \rangle^0 - 5 \langle x - 1200 \rangle^0 + R_2 \langle x - 1500 \rangle^0 \quad (1)$$

$$M = R_1 x - 9 \langle x - 300 \rangle^1 - 5 \langle x - 1200 \rangle^1 + R_2 \langle x - 1500 \rangle^1 \quad (2)$$

At  $x = 1500^+$   $V = M = 0$ . Applying Eqs. (1) and (2),

$$R_1 - 9 - 5 + R_2 = 0 \quad \Rightarrow \quad R_1 + R_2 = 14$$

$$1500R_1 - 9(1500 - 300) - 5(1500 - 1200) = 0 \quad \Rightarrow \quad R_1 = 8.2 \text{ kN} \quad \text{Ans.}$$

$$R_2 = 14 - 8.2 = 5.8 \text{ kN} \quad \text{Ans.}$$

$$0 \leq x \leq 300: \quad V = 8.2 \text{ kN}, \quad M = 8.2x \text{ N} \cdot \text{m}$$

$$300 \leq x \leq 1200: \quad V = 8.2 - 9 = -0.8 \text{ kN}$$

$$M = 8.2x - 9(x - 300) = -0.8x + 2700 \text{ N} \cdot \text{m}$$

$$1200 \leq x \leq 1500: \quad V = 8.2 - 9 - 5 = -5.8 \text{ kN}$$

$$M = 8.2x - 9(x - 300) - 5(x - 1200) = -5.8x + 8700 \text{ N} \cdot \text{m}$$

Plots of  $V$  and  $M$  are the same as in Prob. 3-5.

**3-10**

$$q = R_0 \langle x \rangle^{-1} - M_0 \langle x \rangle^{-2} - 500 \langle x - 8 \rangle^{-1} - 40 \langle x - 14 \rangle^0 + 40 \langle x - 20 \rangle^0$$

$$V = R_0 - M_0 \langle x \rangle^{-1} - 500 \langle x - 8 \rangle^0 - 40 \langle x - 14 \rangle^1 + 40 \langle x - 20 \rangle^1 \quad (1)$$

$$M = R_0 x - M_0 - 500 \langle x - 8 \rangle^1 - 20 \langle x - 14 \rangle^2 + 20 \langle x - 20 \rangle^2 \quad (2)$$

at  $x = 20^+$  in,  $V = M = 0$ , Eqs. (1) and (2) give

$$R_0 - 500 - 40(20 - 14) = 0 \quad \Rightarrow \quad R_0 = 740 \text{ lbf} \quad \text{Ans.}$$

$$R_0(20) - M_0 - 500(20 - 8) - 20(20 - 14)^2 = 0 \quad \Rightarrow \quad M_0 = 8080 \text{ lbf} \cdot \text{in} \quad \text{Ans.}$$

$$0 \leq x \leq 8: \quad V = 740 \text{ lbf}, \quad M = 740x - 8080 \text{ lbf} \cdot \text{in}$$

$$8 \leq x \leq 14: \quad V = 740 - 500 = 240 \text{ lbf}$$

$$M = 740x - 8080 - 500(x - 8) = 240x - 4080 \text{ lbf} \cdot \text{in}$$

$$14 \leq x \leq 20: \quad V = 740 - 500 - 40(x - 14) = -40x + 800 \text{ lbf}$$

$$M = 740x - 8080 - 500(x - 8) - 20(x - 14)^2 = -20x^2 + 800x - 8000 \text{ lbf} \cdot \text{in}$$

Plots of  $V$  and  $M$  are the same as in Prob. 3-6.

---

**3-11**

$$q = R_1 \langle x \rangle^{-1} - 2 \langle x - 1.2 \rangle^{-1} + R_2 \langle x - 2.2 \rangle^{-1} - 4 \langle x - 3.2 \rangle^{-1}$$

$$V = R_1 - 2 \langle x - 1.2 \rangle^0 + R_2 \langle x - 2.2 \rangle^0 - 4 \langle x - 3.2 \rangle^0 \quad (1)$$

$$M = R_1 x - 2 \langle x - 1.2 \rangle^1 + R_2 \langle x - 2.2 \rangle^1 - 4 \langle x - 3.2 \rangle^1 \quad (2)$$

at  $x = 3.2^+$ ,  $V = M = 0$ . Applying Eqs. (1) and (2),

$$R_1 - 2 + R_2 - 4 = 0 \quad \Rightarrow \quad R_1 + R_2 = 6 \quad (3)$$

$$3.2R_1 - 2(2) + R_2(1) = 0 \quad \Rightarrow \quad 3.2R_1 + R_2 = 4 \quad (4)$$

Solving Eqs. (3) and (4) simultaneously,

$$R_1 = -0.91 \text{ kN}, \quad R_2 = 6.91 \text{ kN} \quad \text{Ans.}$$

$$0 \leq x \leq 1.2: \quad V = -0.91 \text{ kN}, \quad M = -0.91x \text{ kN} \cdot \text{m}$$

$$1.2 \leq x \leq 2.2: \quad V = -0.91 - 2 = -2.91 \text{ kN}$$

$$M = -0.91x - 2(x - 1.2) = -2.91x + 2.4 \text{ kN} \cdot \text{m}$$

$$2.2 \leq x \leq 3.2: \quad V = -0.91 - 2 + 6.91 = 4 \text{ kN}$$

$$M = -0.91x - 2(x - 1.2) + 6.91(x - 2.2) = 4x - 12.8 \text{ kN} \cdot \text{m}$$

Plots of  $V$  and  $M$  are the same as in Prob. 3-7.

---

**3-12**

$$q = R_1 \langle x \rangle^{-1} - 400 \langle x-4 \rangle^{-1} + R_2 \langle x-10 \rangle^{-1} - 40 \langle x-10 \rangle^0 + 40 \langle x-20 \rangle^0 + R_3 \langle x-20 \rangle^{-1}$$

$$V = R_1 - 400 \langle x-4 \rangle^0 + R_2 \langle x-10 \rangle^0 - 40 \langle x-10 \rangle^1 + 40 \langle x-20 \rangle^1 + R_3 \langle x-20 \rangle^0 \quad (1)$$

$$M = R_1 x - 400 \langle x-4 \rangle^1 + R_2 \langle x-10 \rangle^1 - 20 \langle x-10 \rangle^2 + 20 \langle x-20 \rangle^2 + R_3 \langle x-20 \rangle^1 \quad (2)$$

$$M = 0 \text{ at } x = 8 \text{ in } \therefore 8R_1 - 400(8-4) = 0 \quad \Rightarrow \quad R_1 = 200 \text{ lbf} \quad \text{Ans.}$$

at  $x = 20^+$ ,  $V = M = 0$ . Applying Eqs. (1) and (2),

$$200 - 400 + R_2 - 40(10) + R_3 = 0 \quad \Rightarrow \quad R_2 + R_3 = 600$$

$$200(20) - 400(16) + R_2(10) - 20(10)^2 = 0 \quad \Rightarrow \quad R_2 = 440 \text{ lbf} \quad \text{Ans.}$$

$$R_3 = 600 - 440 = 160 \text{ lbf} \quad \text{Ans.}$$

$$0 \leq x \leq 4: \quad V = 200 \text{ lbf}, \quad M = 200x \text{ lbf} \cdot \text{in}$$

$$4 \leq x \leq 10: \quad V = 200 - 400 = -200 \text{ lbf},$$

$$M = 200x - 400(x-4) = -200x + 1600 \text{ lbf} \cdot \text{in}$$

$$10 \leq x \leq 20: \quad V = 200 - 400 + 440 - 40(x-10) = 640 - 40x \text{ lbf}$$

$$M = 200x - 400(x-4) + 440(x-10) - 20(x-10)^2 = -20x^2 + 640x - 4800 \text{ lbf} \cdot \text{in}$$

Plots of  $V$  and  $M$  are the same as in Prob. 3-8.

**3-13** Solution depends upon the beam selected.

**3-14**

(a) Moment at center,

$$x_c = \frac{(l-2a)}{2}$$

$$M_c = \frac{w}{2} \left[ \frac{l}{2}(l-2a) - \left( \frac{l}{2} \right)^2 \right] = \frac{wl}{2} \left( \frac{l}{4} - a \right)$$

$$\text{At reaction, } |M_r| = wa^2/2$$

$$a = 2.25, \quad l = 10 \text{ in}, \quad w = 100 \text{ lbf/in}$$

$$M_c = \frac{100(10)}{2} \left( \frac{10}{4} - 2.25 \right) = 125 \text{ lbf} \cdot \text{in}$$

$$|M_r| = \frac{100(2.25^2)}{2} = 253 \text{ lbf} \cdot \text{in} \quad \text{Ans.}$$

(b) Optimal occurs when  $M_c = |M_r|$



$$\frac{wl}{2} \left( \frac{l}{4} - a \right) = \frac{wa^2}{2} \Rightarrow a^2 + al - 0.25l^2 = 0$$

Taking the positive root

$$a = \frac{1}{2} \left[ -l + \sqrt{l^2 + 4(0.25l^2)} \right] = \frac{l}{2} (\sqrt{2} - 1) = 0.207 l \quad \text{Ans.}$$

for  $l = 10$  in,  $w = 100$  lbf,  $a = 0.207(10) = 2.07$  in

$$M_{\min} = (100/2)2.07^2 = 214 \text{ lbf} \cdot \text{in}$$

### 3-15

(a)

$$C = \frac{20 - 10}{2} = 5 \text{ kpsi}$$

$$CD = \frac{20 + 10}{2} = 15 \text{ kpsi}$$

$$R = \sqrt{15^2 + 8^2} = 17 \text{ kpsi}$$

$$\sigma_1 = 5 + 17 = 22 \text{ kpsi}$$

$$\sigma_2 = 5 - 17 = -12 \text{ kpsi}$$

$$\phi_p = \frac{1}{2} \tan^{-1} \left( \frac{8}{15} \right) = 14.04^\circ \text{ cw}$$

$$\tau_1 = R = 17 \text{ kpsi}$$

$$\phi_s = 45^\circ - 14.04^\circ = 30.96^\circ \text{ ccw}$$

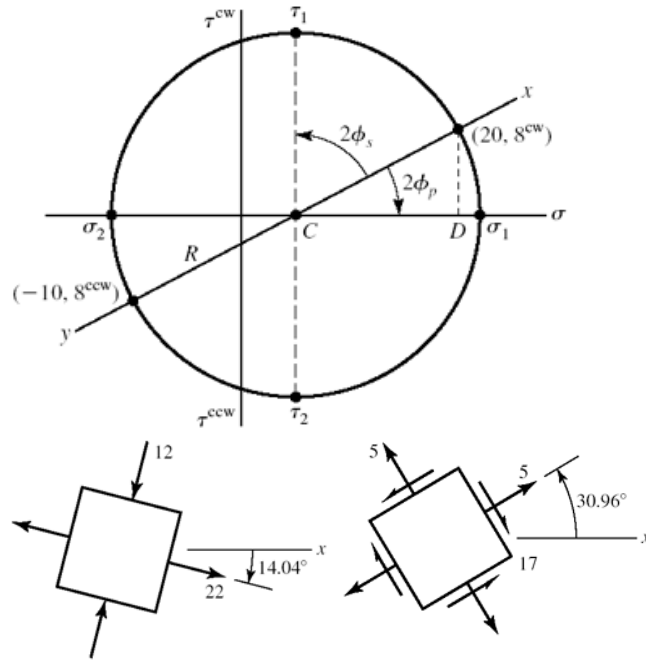

(b)

$$C = \frac{9 + 16}{2} = 12.5 \text{ kpsi}$$

$$CD = \frac{16 - 9}{2} = 3.5 \text{ kpsi}$$

$$R = \sqrt{5^2 + 3.5^2} = 6.10 \text{ kpsi}$$

$$\sigma_1 = 12.5 + 6.1 = 18.6 \text{ kpsi}$$

$$\sigma_2 = 12.5 - 6.1 = 6.4 \text{ kpsi}$$

$$\phi_p = \frac{1}{2} \tan^{-1} \left( \frac{5}{3.5} \right) = 27.5^\circ \text{ ccw}$$

$$\tau_1 = R = 6.10 \text{ kpsi}$$

$$\phi_s = 45^\circ - 27.5^\circ = 17.5^\circ \text{ cw}$$

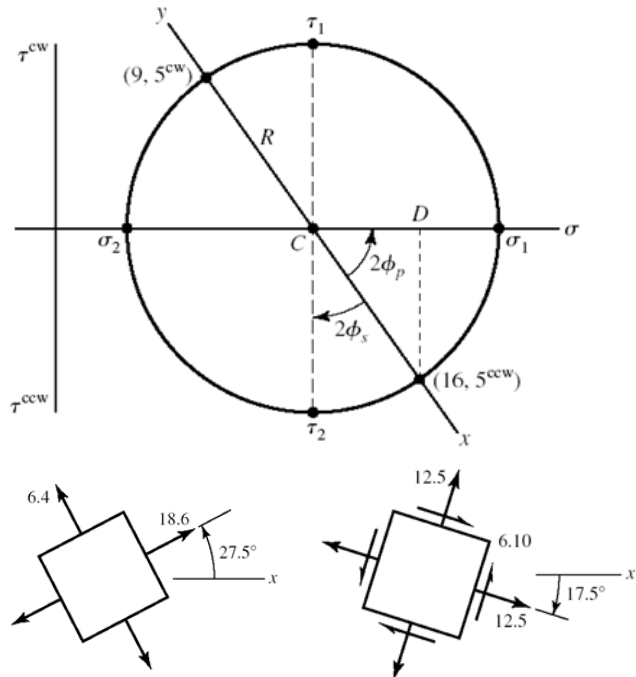

(c)

$$C = \frac{24 + 10}{2} = 17 \text{ kpsi}$$

$$CD = \frac{24 - 10}{2} = 7 \text{ kpsi}$$

$$R = \sqrt{7^2 + 6^2} = 9.22 \text{ kpsi}$$

$$\sigma_1 = 17 + 9.22 = 26.22 \text{ kpsi}$$

$$\sigma_2 = 17 - 9.22 = 7.78 \text{ kpsi}$$

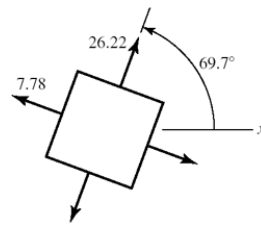
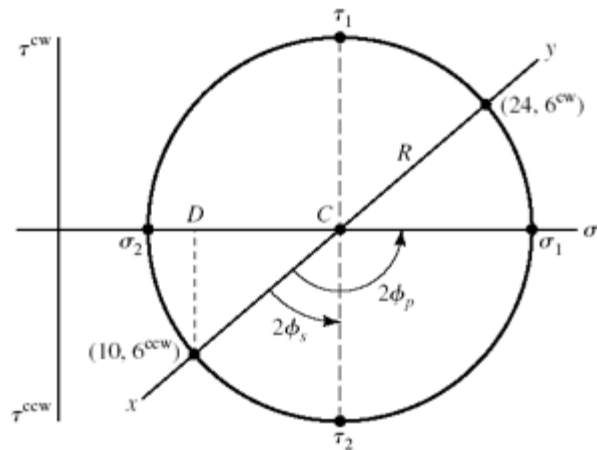

$$\phi_p = \frac{1}{2} \left[ 90^\circ + \tan^{-1} \left( \frac{7}{6} \right) \right] = 69.7^\circ \text{ ccw}$$

$$\tau_1 = R = 9.22 \text{ kpsi}$$

$$\phi_s = 69.7^\circ - 45^\circ = 24.7^\circ \text{ ccw}$$

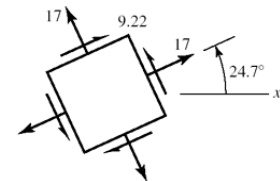

(d)

$$C = \frac{-12 + 22}{2} = 5 \text{ kpsi}$$

$$CD = \frac{12 + 22}{2} = 17 \text{ kpsi}$$

$$R = \sqrt{17^2 + 12^2} = 20.81 \text{ kpsi}$$

$$\sigma_1 = 5 + 20.81 = 25.81 \text{ kpsi}$$

$$\sigma_2 = 5 - 20.81 = -15.81 \text{ kpsi}$$

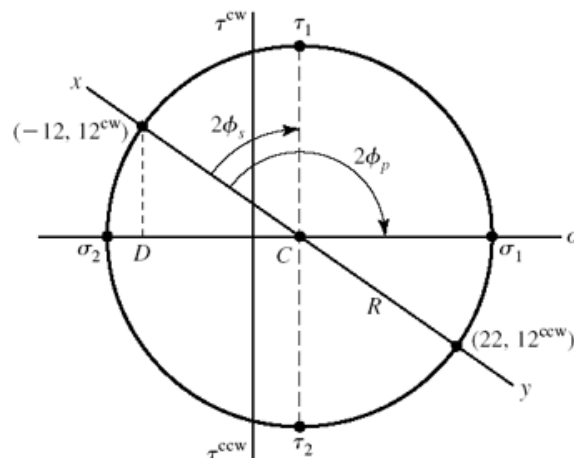

$$\phi_p = \frac{1}{2} \left[ 90^\circ + \tan^{-1} \left( \frac{17}{12} \right) \right] = 72.39^\circ \text{ cw}$$

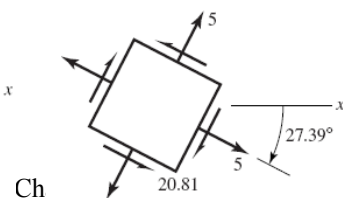
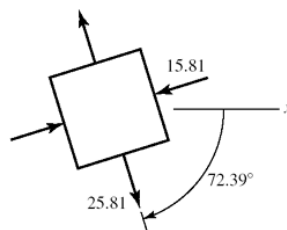

$$\tau_1 = R = 20.81 \text{ kpsi}$$

$$\phi_s = 72.39 - 45 = 27.39^\circ \text{ cw}$$

---

3-16

(a)

$$C = \frac{-8+7}{2} = -0.5 \text{ MPa}$$

$$CD = \frac{8+7}{2} = 7.5 \text{ MPa}$$

$$R = \sqrt{7.5^2 + 6^2} = 9.60 \text{ MPa}$$

$$\sigma_1 = 9.60 - 0.5 = 9.10 \text{ MPa}$$

$$\sigma_2 = -0.5 - 9.6 = -10.1 \text{ MPa}$$

$$\phi_p = \frac{1}{2} \left[ 90^\circ + \tan^{-1} \left( \frac{7.5}{6} \right) \right] = 70.67^\circ \text{ cw}$$

$$\tau_1 = R = 9.60 \text{ MPa}$$

$$\phi_s = 70.67^\circ - 45^\circ = 25.67^\circ \text{ cw}$$

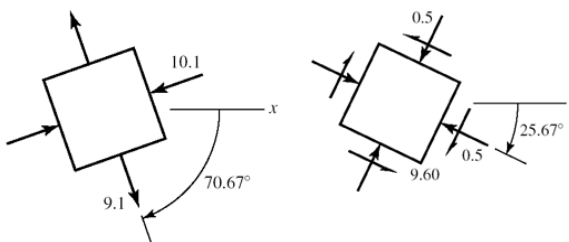
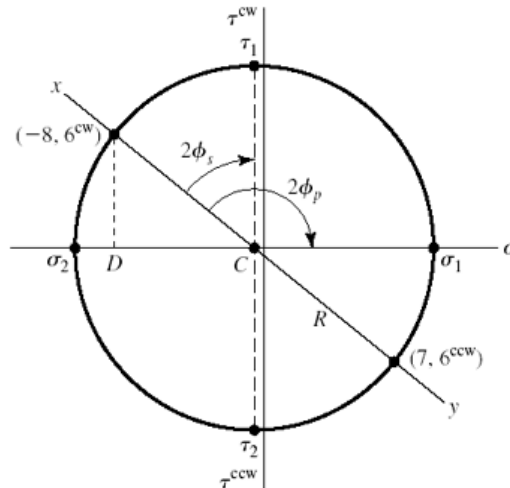

(b)

$$C = \frac{9-6}{2} = 1.5 \text{ MPa}$$

$$CD = \frac{9+6}{2} = 7.5 \text{ MPa}$$

$$R = \sqrt{7.5^2 + 3^2} = 8.078 \text{ MPa}$$

$$\sigma_1 = 1.5 + 8.078 = 9.58 \text{ MPa}$$

$$\sigma_2 = 1.5 - 8.078 = -6.58 \text{ MPa}$$

$$\phi_p = \frac{1}{2} \tan^{-1} \left( \frac{3}{7.5} \right) = 10.9^\circ \text{ cw}$$

$$\tau_1 = R = 8.078 \text{ MPa}$$

$$\phi_s = 45^\circ - 10.9^\circ = 34.1^\circ \text{ ccw}$$

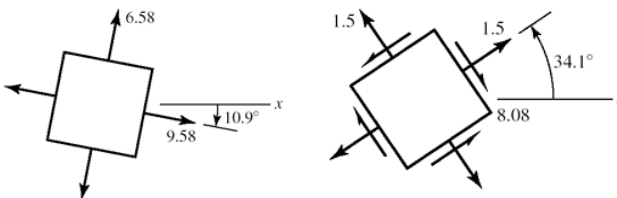
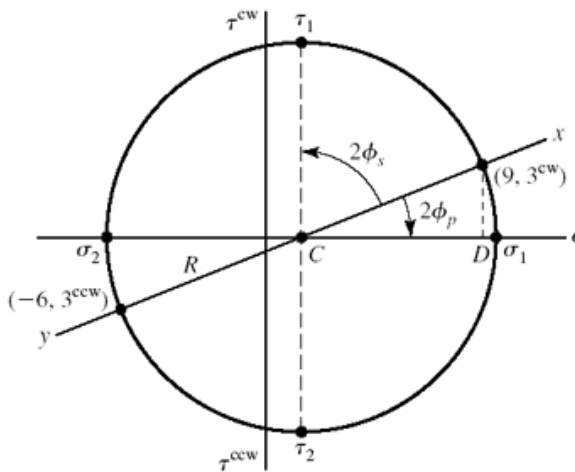

(c)

$$C = \frac{12 - 4}{2} = 4 \text{ MPa}$$

$$CD = \frac{12 + 4}{2} = 8 \text{ MPa}$$

$$R = \sqrt{8^2 + 7^2} = 10.63 \text{ MPa}$$

$$\sigma_1 = 4 + 10.63 = 14.63 \text{ MPa}$$

$$\sigma_2 = 4 - 10.63 = -6.63 \text{ MPa}$$

$$\phi_p = \frac{1}{2} \left[ 90^\circ + \tan^{-1} \left( \frac{8}{7} \right) \right] = 69.4^\circ \text{ ccw}$$

$$\tau_1 = R = 10.63 \text{ MPa}$$

$$\phi_s = 69.4^\circ - 45^\circ = 24.4^\circ \text{ ccw}$$

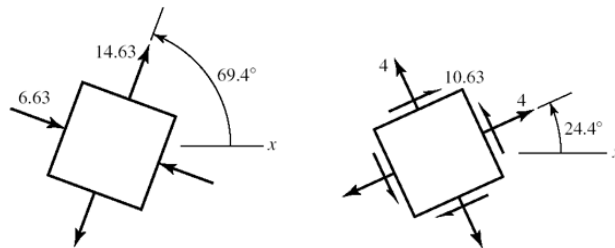
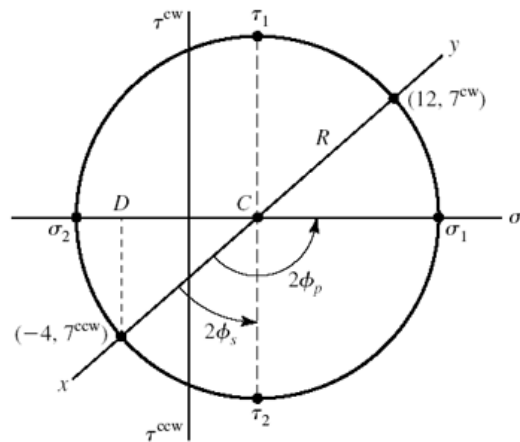

(d)

$$C = \frac{6 - 5}{2} = 0.5 \text{ MPa}$$

$$CD = \frac{6 + 5}{2} = 5.5 \text{ MPa}$$

$$R = \sqrt{5.5^2 + 8^2} = 9.71 \text{ MPa}$$

$$\sigma_1 = 0.5 + 9.71 = 10.21 \text{ MPa}$$

$$\sigma_2 = 0.5 - 9.71 = -9.21 \text{ MPa}$$

$$\phi_p = \frac{1}{2} \tan^{-1} \left( \frac{8}{5.5} \right) = 27.75^\circ \text{ ccw}$$

$$\tau_1 = R = 9.71 \text{ MPa}$$

$$\phi_s = 45^\circ - 27.75^\circ = 17.25^\circ \text{ cw}$$

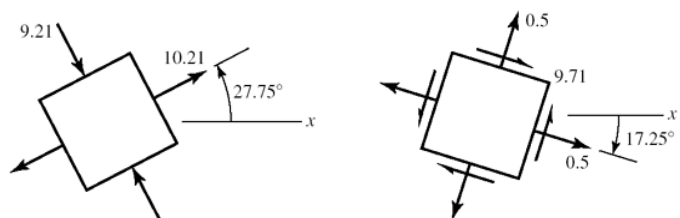
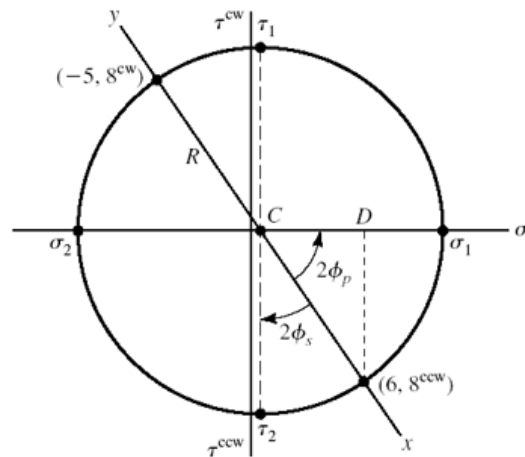

3-17

(a)

$$C = \frac{12+6}{2} = 9 \text{ kpsi}$$

$$CD = \frac{12-6}{2} = 3 \text{ kpsi}$$

$$R = \sqrt{3^2 + 4^2} = 5 \text{ kpsi}$$

$$\sigma_1 = 5 + 9 = 14 \text{ kpsi}$$

$$\sigma_2 = 9 - 5 = 4 \text{ kpsi}$$

$$\phi_p = \frac{1}{2} \tan^{-1} \left( \frac{4}{3} \right) = 26.6^\circ \text{ ccw}$$

$$\tau_1 = R = 5 \text{ kpsi}$$

$$\phi_s = 45^\circ - 26.6^\circ = 18.4^\circ \text{ ccw}$$

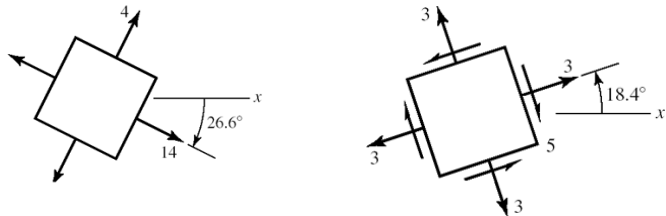
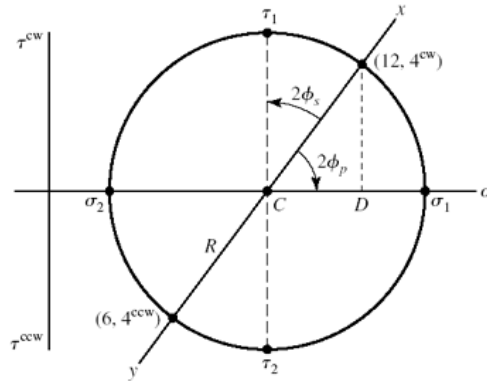

(b)

$$C = \frac{30-10}{2} = 10 \text{ kpsi}$$

$$CD = \frac{30+10}{2} = 20 \text{ kpsi}$$

$$R = \sqrt{20^2 + 10^2} = 22.36 \text{ kpsi}$$

$$\sigma_1 = 10 + 22.36 = 32.36 \text{ kpsi}$$

$$\sigma_2 = 10 - 22.36 = -12.36 \text{ kpsi}$$

$$\phi_p = \frac{1}{2} \tan^{-1} \left( \frac{10}{20} \right) = 13.28^\circ \text{ ccw}$$

$$\tau_1 = R = 22.36 \text{ kpsi}$$

$$\phi_s = 45^\circ - 13.28^\circ = 31.72^\circ \text{ cw}$$

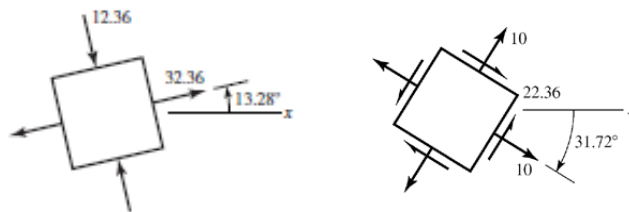
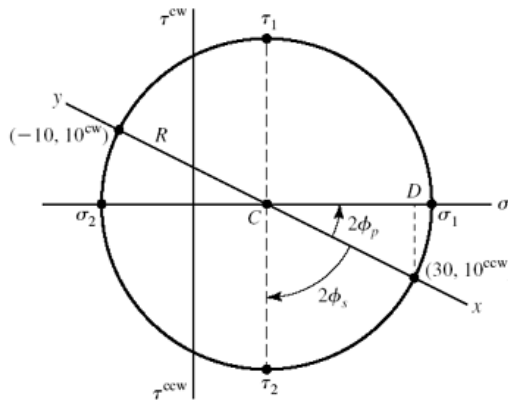

(c)

$$C = \frac{-10 + 18}{2} = 4 \text{ kpsi}$$

$$CD = \frac{10 + 18}{2} = 14 \text{ kpsi}$$

$$R = \sqrt{14^2 + 9^2} = 16.64 \text{ kpsi}$$

$$\sigma_1 = 4 + 16.64 = 20.64 \text{ kpsi}$$

$$\sigma_2 = 4 - 16.64 = -12.64 \text{ kpsi}$$

$$\phi_p = \frac{1}{2} \left[ 90^\circ + \tan^{-1} \left( \frac{14}{9} \right) \right] = 73.63^\circ \text{ cw}$$

$$\tau_1 = R = 16.64 \text{ kpsi}$$

$$\phi_s = 73.63 - 45 = 28.63^\circ \text{ cw}$$

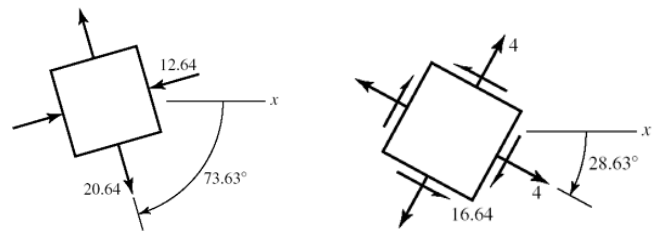
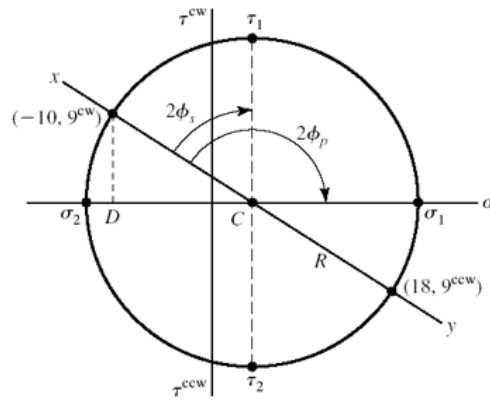

(d)

$$C = \frac{9 + 19}{2} = 14 \text{ kpsi}$$

$$CD = \frac{19 - 9}{2} = 5 \text{ kpsi}$$

$$R = \sqrt{5^2 + 8^2} = 9.434 \text{ kpsi}$$

$$\sigma_1 = 14 + 9.43 = 23.43 \text{ kpsi}$$

$$\sigma_2 = 14 - 9.43 = 4.57 \text{ kpsi}$$

$$\phi_p = \frac{1}{2} \left[ 90^\circ + \tan^{-1} \left( \frac{5}{8} \right) \right] = 61.0^\circ \text{ cw}$$

$$\tau_1 = R = 9.34 \text{ kpsi}$$

$$\phi_s = 61^\circ - 45^\circ = 16^\circ \text{ cw}$$

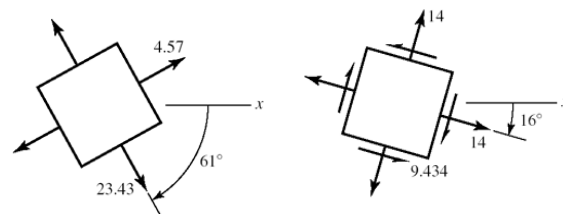
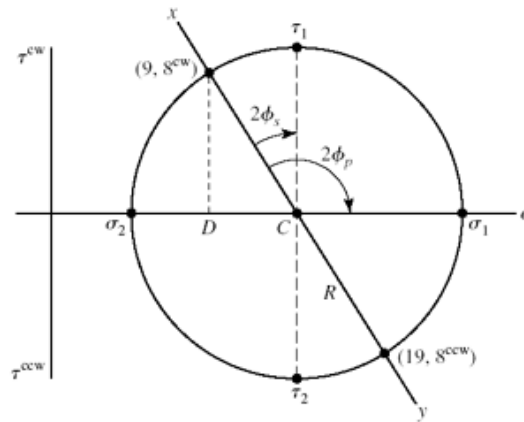

3-18

(a)

$$C = \frac{-80 - 30}{2} = -55 \text{ MPa}$$

$$CD = \frac{80 - 30}{2} = 25 \text{ MPa}$$

$$R = \sqrt{25^2 + 20^2} = 32.02 \text{ MPa}$$

$$\sigma_1 = 0 \text{ MPa}$$

$$\sigma_2 = -55 + 32.02 = -22.98 = -23.0 \text{ MPa}$$

$$\sigma_3 = -55 - 32.0 = -87.0 \text{ MPa}$$

$$\tau_{1/2} = \frac{23}{2} = 11.5 \text{ MPa}, \quad \tau_{2/3} = 32.0 \text{ MPa}, \quad \tau_{1/3} = \frac{87}{2} = 43.5 \text{ MPa}$$

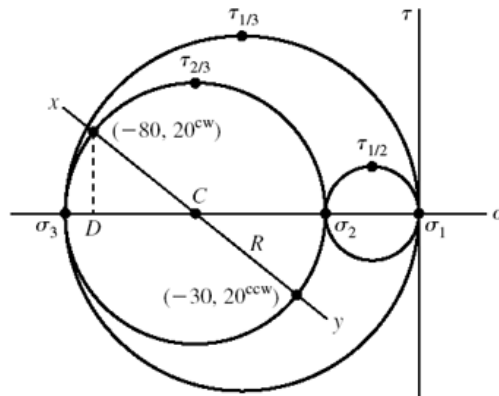

(b)

$$C = \frac{30 - 60}{2} = -15 \text{ MPa}$$

$$CD = \frac{60 + 30}{2} = 45 \text{ MPa}$$

$$R = \sqrt{45^2 + 30^2} = 54.1 \text{ MPa}$$

$$\sigma_1 = -15 + 54.1 = 39.1 \text{ MPa}$$

$$\sigma_2 = 0 \text{ MPa}$$

$$\sigma_3 = -15 - 54.1 = -69.1 \text{ MPa}$$

$$\tau_{1/3} = \frac{39.1 + 69.1}{2} = 54.1 \text{ MPa}$$

$$\tau_{1/2} = \frac{39.1}{2} = 19.6 \text{ MPa}$$

$$\tau_{2/3} = \frac{69.1}{2} = 34.6 \text{ MPa}$$

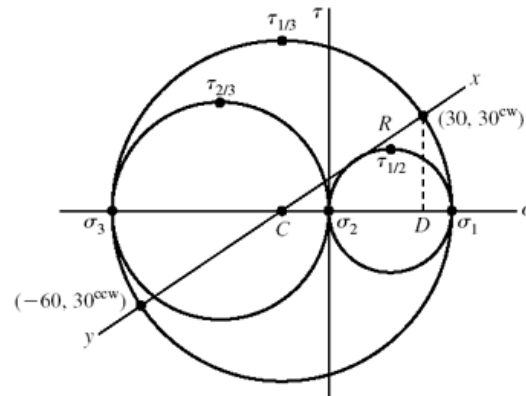



(c)

$$C = \frac{40 + 0}{2} = 20 \text{ MPa}$$

$$CD = \frac{40 - 0}{2} = 20 \text{ MPa}$$

$$R = \sqrt{20^2 + 20^2} = 28.3 \text{ MPa}$$

$$\sigma_1 = 20 + 28.3 = 48.3 \text{ MPa}$$

$$\sigma_2 = 20 - 28.3 = -8.3 \text{ MPa}$$

$$\sigma_3 = \sigma_z = -30 \text{ MPa}$$

$$\tau_{1/3} = \frac{48.3 + 30}{2} = 39.1 \text{ MPa}, \quad \tau_{1/2} = 28.3 \text{ MPa}, \quad \tau_{2/3} = \frac{30 - 8.3}{2} = 10.9 \text{ MPa}$$

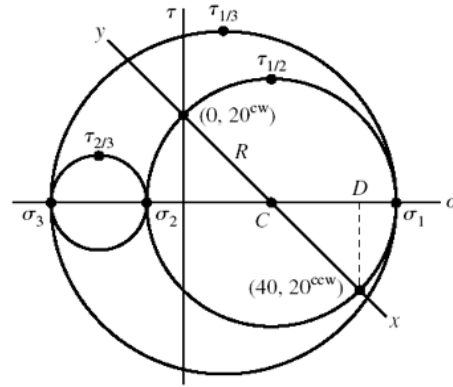

(d)

$$C = \frac{50}{2} = 25 \text{ MPa}$$

$$CD = \frac{50}{2} = 25 \text{ MPa}$$

$$R = \sqrt{25^2 + 30^2} = 39.1 \text{ MPa}$$

$$\sigma_1 = 25 + 39.1 = 64.1 \text{ MPa}$$

$$\sigma_2 = 25 - 39.1 = -14.1 \text{ MPa}$$

$$\sigma_3 = \sigma_z = -20 \text{ MPa}$$

$$\tau_{1/3} = \frac{64.1 + 20}{2} = 42.1 \text{ MPa}, \quad \tau_{1/2} = 39.1 \text{ MPa}, \quad \tau_{2/3} = \frac{20 - 14.1}{2} = 2.95 \text{ MPa}$$

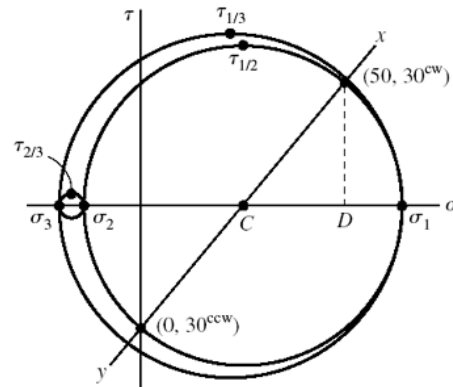

### 3-19

(a)

Since there are no shear stresses on the stress element, the stress element already represents principal stresses.

$$\sigma_1 = \sigma_x = 10 \text{ kpsi}$$

$$\sigma_2 = 0 \text{ kpsi}$$

$$\sigma_3 = \sigma_y = -4 \text{ kpsi}$$

$$\tau_{1/3} = \frac{10 - (-4)}{2} = 7 \text{ kpsi}$$

$$\tau_{1/2} = \frac{10}{2} = 5 \text{ kpsi}$$

$$\tau_{2/3} = \frac{0 - (-4)}{2} = 2 \text{ kpsi}$$

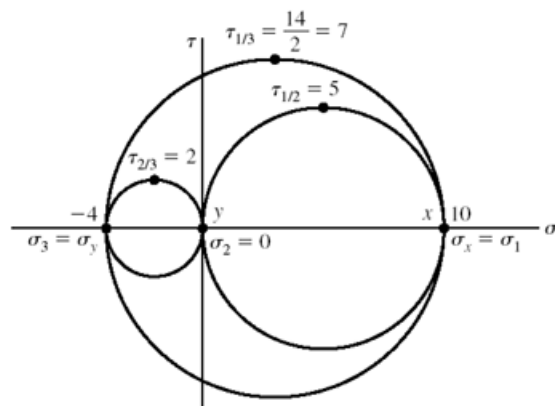

(b)

$$C = \frac{0+10}{2} = 5 \text{ kpsi}$$

$$CD = \frac{10-0}{2} = 5 \text{ kpsi}$$

$$R = \sqrt{5^2 + 4^2} = 6.40 \text{ kpsi}$$

$$\sigma_1 = 5 + 6.40 = 11.40 \text{ kpsi}$$

$$\sigma_2 = 0 \text{ kpsi}, \quad \sigma_3 = 5 - 6.40 = -1.40 \text{ kpsi}$$

$$\tau_{1/3} = R = 6.40 \text{ kpsi}, \quad \tau_{1/2} = \frac{11.40}{2} = 5.70 \text{ kpsi}, \quad \tau_3 = \frac{1.40}{2} = 0.70 \text{ kpsi}$$

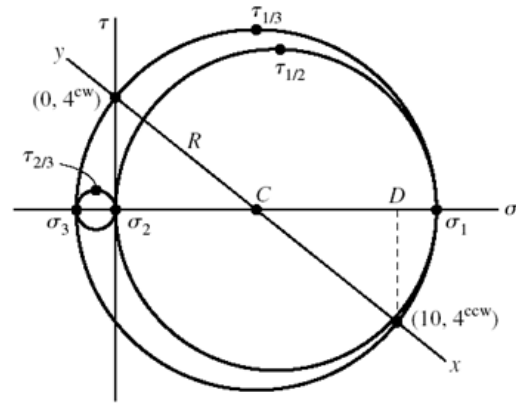

(c)

$$C = \frac{-2-8}{2} = -5 \text{ kpsi}$$

$$CD = \frac{8-2}{2} = 3 \text{ kpsi}$$

$$R = \sqrt{3^2 + 4^2} = 5 \text{ kpsi}$$

$$\sigma_1 = -5 + 5 = 0 \text{ kpsi}, \quad \sigma_2 = 0 \text{ kpsi}$$

$$\sigma_3 = -5 - 5 = -10 \text{ kpsi}$$

$$\tau_{1/3} = \frac{10}{2} = 5 \text{ kpsi}, \quad \tau_{1/2} = 0 \text{ kpsi}, \quad \tau_{2/3} = 5 \text{ kpsi}$$

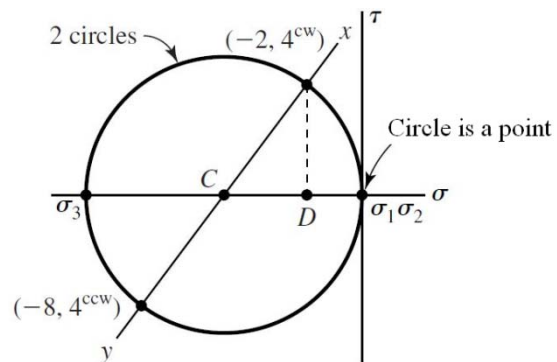

(d)

$$C = \frac{10-30}{2} = -10 \text{ kpsi}$$

$$CD = \frac{10+30}{2} = 20 \text{ kpsi}$$

$$R = \sqrt{20^2 + 10^2} = 22.36 \text{ kpsi}$$

$$\sigma_1 = -10 + 22.36 = 12.36 \text{ kpsi}$$

$$\sigma_2 = 0 \text{ kpsi}$$

$$\sigma_3 = -10 - 22.36 = -32.36 \text{ kpsi}$$

$$\tau_{1/3} = 22.36 \text{ kpsi}, \quad \tau_{1/2} = \frac{12.36}{2} = 6.18 \text{ kpsi}, \quad \tau_{2/3} = \frac{32.36}{2} = 16.18 \text{ kpsi}$$

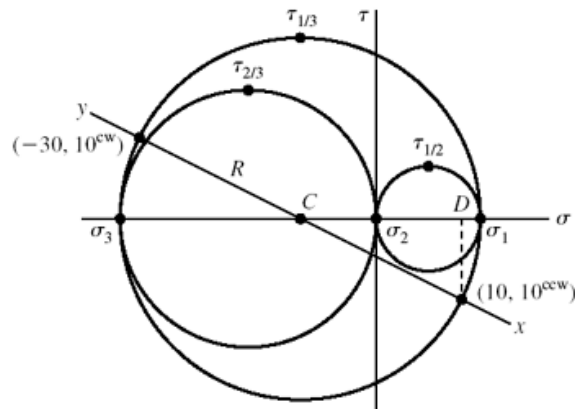

**3-20** From Eq. (3-15),

$$\begin{aligned} \sigma^3 - (-6+18-12)\sigma^2 + [-6(18) + (-6)(-12) + 18(-12) - 9^2 - 6^2 - (-15)^2] \sigma \\ - [-6(18)(-12) + 2(9)(6)(-15) - (-6)(6)^2 - 18(-15)^2 - (-12)(9)^2] = 0 \\ \sigma^3 - 594\sigma + 3186 = 0 \end{aligned}$$

Roots are: 21.04, 5.67, -26.71 kpsi *Ans.*

$$\tau_{1/2} = \frac{21.04 - 5.67}{2} = 7.69 \text{ kpsi}$$

$$\tau_{2/3} = \frac{5.67 + 26.71}{2} = 16.19 \text{ kpsi}$$

$$\tau_{\max} = \tau_{1/3} = \frac{21.04 + 26.71}{2} = 23.88 \text{ kpsi} \quad \textit{Ans.}$$

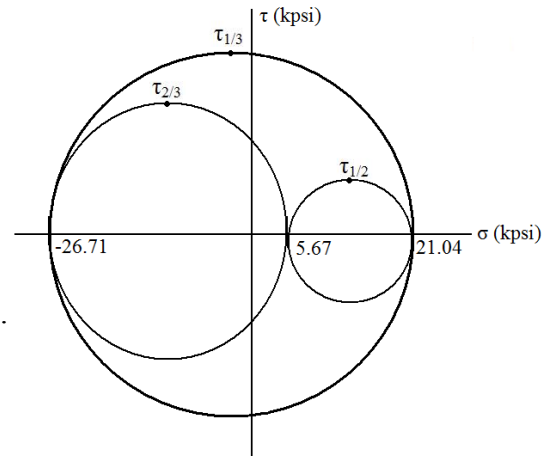

**3-21**

From Eq. (3-15)

$$\begin{aligned} \sigma^3 - (20+0+20)\sigma^2 + [20(0) + 20(20) + 0(20) - 40^2 - (-20\sqrt{2})^2 - 0^2] \sigma \\ - [20(0)(20) + 2(40)(-20\sqrt{2})(0) - 20(-20\sqrt{2})^2 - 0(0)^2 - 20(40)^2] = 0 \\ \sigma^3 - 40\sigma^2 - 2\,000\sigma + 48\,000 = 0 \end{aligned}$$

Roots are: 60, 20, -40 kpsi *Ans.*

$$\tau_{1/2} = \frac{60 - 20}{2} = 20 \text{ kpsi}$$

$$\tau_{2/3} = \frac{20 + 40}{2} = 30 \text{ kpsi}$$

$$\tau_{\max} = \tau_{1/3} = \frac{60 + 40}{2} = 50 \text{ kpsi} \quad \textit{Ans.}$$

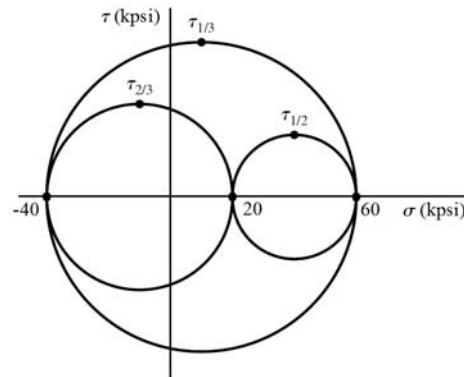

**3-22**

From Eq. (3-15)

$$\begin{aligned} \sigma^3 - (10 + 40 + 40)\sigma^2 + [10(40) + 10(40) + 40(40) - 20^2 - (-40)^2 - (-20)^2] \sigma \\ - [10(40)(40) + 2(20)(-40)(-20) - 10(-40)^2 - 40(-20)^2 - 40(20)^2] = 0 \\ \sigma^3 - 90\sigma^2 = 0 \end{aligned}$$

Roots are: 90, 0, 0 MPa      *Ans.*

$$\tau_{2/3} = 0$$

$$\tau_{1/2} = \tau_{1/3} = \tau_{\max} = \frac{90}{2} = 45 \text{ MPa} \quad \textit{Ans.}$$

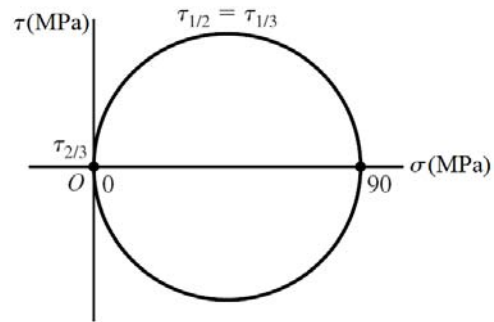

**3-23**

$$\sigma = \frac{F}{A} = \frac{15000}{(\pi/4)(0.75^2)} = 33\,950 \text{ psi} = 34.0 \text{ kpsi} \quad \textit{Ans.}$$

$$\delta = \frac{FL}{AE} = \sigma \frac{L}{E} = 33\,950 \frac{60}{30(10^6)} = 0.0679 \text{ in} \quad \textit{Ans.}$$

$$\epsilon_1 = \frac{\delta}{L} = \frac{0.0679}{60} = 1130(10^{-6}) = 1130 \mu \quad \textit{Ans.}$$

From Table A-5,  $\nu = 0.292$

$$\epsilon_2 = -\nu\epsilon_1 = -0.292(1130) = -330 \mu \quad \textit{Ans.}$$

$$\Delta d = \epsilon_2 d = -330(10^{-6})(0.75) = -248(10^{-6}) \text{ in} \quad \textit{Ans.}$$

**3-24**

$$\sigma = \frac{F}{A} = \frac{3000}{(\pi/4)(0.75^2)} = 6790 \text{ psi} = 6.79 \text{ kpsi} \quad \textit{Ans.}$$

$$\delta = \frac{FL}{AE} = \sigma \frac{L}{E} = 6790 \frac{60}{10.4(10^6)} = 0.0392 \text{ in} \quad \textit{Ans.}$$

$$\epsilon_1 = \frac{\delta}{L} = \frac{0.0392}{60} = 653(10^{-6}) = 653 \mu \quad \textit{Ans.}$$

From Table A-5,  $\nu = 0.333$

$$\epsilon_2 = -\nu\epsilon_1 = -0.333(653) = -217 \mu \quad \textit{Ans.}$$

$$\Delta d = \epsilon_2 d = -217(10^{-6})(0.75) = -163(10^{-6}) \text{ in} \quad \textit{Ans.}$$

---

**3-25**

$$\epsilon_2 = \frac{\Delta d}{d} = \frac{-0.0001d}{d} = -0.0001$$

From Table A-5,  $\nu = 0.326$ ,  $E = 119 \text{ GPa}$

$$\epsilon_1 = \frac{-\epsilon_2}{\nu} = \frac{-0.0001}{0.326} = 306.7(10^{-6})$$

$$\delta = \frac{FL}{AE} \quad \text{and} \quad \sigma = \frac{F}{A}, \quad \text{so}$$

$$\sigma = \frac{\delta E}{L} = \epsilon_1 E = 306.7(10^{-6})(119)(10^9) = 36.5 \text{ MPa}$$

$$F = \sigma A = 36.5(10^6) \frac{\pi(0.03)^2}{4} = 25\,800 \text{ N} = 25.8 \text{ kN} \quad \text{Ans.}$$

$S_y = 70 \text{ MPa} > \sigma$ , so elastic deformation assumption is valid.

---

**3-26**

$$\delta = \frac{FL}{AE} = \sigma \frac{L}{E} = 20\,000 \frac{8(12)}{10.4(10^6)} = 0.185 \text{ in} \quad \text{Ans.}$$

---

**3-27**

$$\delta = \frac{FL}{AE} = \sigma \frac{L}{E} = 140(10^6) \frac{3}{71.7(10^9)} = 0.00586 \text{ m} = 5.86 \text{ mm} \quad \text{Ans.}$$

---

**3-28**

$$\delta = \frac{FL}{AE} = \sigma \frac{L}{E} = 15\,000 \frac{10(12)}{10.4(10^6)} = 0.173 \text{ in} \quad \text{Ans.}$$

---

**3-29**

With  $\sigma_z = 0$ , solve the first two equations of Eq. (3-19) simultaneously. Place  $E$  on the left-hand side of both equations, and using Cramer's rule,

$$\sigma_x = \frac{\begin{vmatrix} E\epsilon_x & -\nu \\ E\epsilon_y & 1 \end{vmatrix}}{\begin{vmatrix} 1 & -\nu \\ -\nu & 1 \end{vmatrix}} = \frac{E\epsilon_x + \nu E\epsilon_y}{1 - \nu^2} = \frac{E(\epsilon_x + \nu\epsilon_y)}{1 - \nu^2}$$

Likewise,

$$\sigma_y = \frac{E(\epsilon_y + \nu\epsilon_x)}{1 - \nu^2}$$

From Table A-5,  $E = 207$  GPa and  $\nu = 0.292$ . Thus,

$$\sigma_x = \frac{E(\epsilon_x + \nu\epsilon_y)}{1 - \nu^2} = \frac{207(10^9)[0.0019 + 0.292(-0.00072)]}{1 - 0.292^2}(10^{-6}) = 382 \text{ MPa} \quad \text{Ans.}$$

$$\sigma_y = \frac{207(10^9)[-0.00072 + 0.292(0.0019)]}{1 - 0.292^2}(10^{-6}) = -37.4 \text{ MPa} \quad \text{Ans.}$$

### 3-30

With  $\sigma_z = 0$ , solve the first two equations of Eq. (3-19) simultaneously. Place  $E$  on the left-hand side of both equations, and using Cramer's rule,

$$\sigma_x = \frac{\begin{vmatrix} E\epsilon_x & -\nu \\ E\epsilon_y & 1 \end{vmatrix}}{\begin{vmatrix} 1 & -\nu \\ -\nu & 1 \end{vmatrix}} = \frac{E\epsilon_x + \nu E\epsilon_y}{1 - \nu^2} = \frac{E(\epsilon_x + \nu\epsilon_y)}{1 - \nu^2}$$

Likewise,

$$\sigma_y = \frac{E(\epsilon_y + \nu\epsilon_x)}{1 - \nu^2}$$

From Table A-5,  $E = 71.7$  GPa and  $\nu = 0.333$ . Thus,

$$\sigma_x = \frac{E(\epsilon_x + \nu\epsilon_y)}{1 - \nu^2} = \frac{71.7(10^9)[0.0019 + 0.333(-0.00072)]}{1 - 0.333^2}(10^{-6}) = 134 \text{ MPa} \quad \text{Ans.}$$

$$\sigma_y = \frac{71.7(10^9)[-0.00072 + 0.333(0.0019)]}{1 - 0.333^2}(10^{-6}) = -7.04 \text{ MPa} \quad \text{Ans.}$$

### 3-31

$$(a) \quad R_1 = \frac{c}{l}F \quad M_{\max} = R_1a = \frac{ac}{l}F$$

$$\sigma = \frac{6M}{bh^2} = \frac{6}{bh^2} \frac{ac}{l}F \Rightarrow F = \frac{\sigma bh^2 l}{6ac} \quad \text{Ans.}$$

$$(b) \quad \frac{F_m}{F} = \frac{(\sigma_m/\sigma)(b_m/b)(h_m/h)^2(l_m/l_1)}{(a_m/a)(c_m/c)} = \frac{1(s)(s)^2(s)}{(s)(s)} = s^2 \quad \text{Ans.}$$

For equal stress, the model load varies by the square of the scale factor.

### 3-32

$$(a) \quad R_1 = \frac{wl}{2}, \quad M_{\max}|_{x=l/2} = \frac{wl}{2} \frac{l}{2} \left( l - \frac{l}{2} \right) = \frac{wl^2}{8}$$

$$\sigma = \frac{6M}{bh^2} = \frac{6}{bh^2} \frac{wl^2}{8} = \frac{3Wl}{4bh^2} \Rightarrow W = \frac{4}{3} \frac{\sigma bh^2}{l} \quad \text{Ans.}$$

$$(b) \quad \frac{W_m}{W} = \frac{(\sigma_m / \sigma)(b_m / b)(h_m / h)^2}{l_m / l} = \frac{1(s)(s)^2}{s} = s^2 \quad \text{Ans.}$$

$$\frac{w_m l_m}{wl} = s^2 \Rightarrow \frac{w_m}{w} = \frac{s^2}{s} = s \quad \text{Ans.}$$

For equal stress, the model load  $w$  varies linearly with the scale factor.

### 3-33

(a) Can solve by iteration *or* derive equations for the general case. Find maximum moment under wheel  $W_3$ .

$$W_T = \Sigma W \text{ at centroid of } W's$$

$$R_A = \frac{l - x_3 - d_3}{l} W_T$$

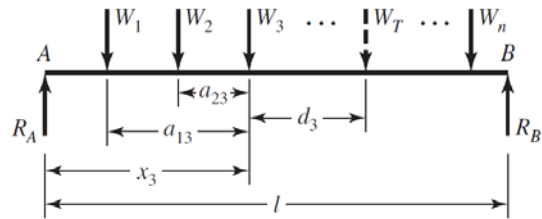

Under wheel 3,

$$M_3 = R_A x_3 - W_1 a_{13} - W_2 a_{23} = \frac{(l - x_3 - d_3)}{l} W_T x_3 - W_1 a_{13} - W_2 a_{23}$$

$$\text{For maximum, } \frac{dM_3}{dx_3} = 0 = (l - d_3 - 2x_3) \frac{W_T}{l} \Rightarrow x_3 = \frac{l - d_3}{2}$$

$$\text{Substitute into } M \Rightarrow M_3 = \frac{(l - d_3)^2}{4l} W_T - W_1 a_{13} - W_2 a_{23}$$

This means the midpoint of  $d_3$  intersects the midpoint of the beam.

$$\text{For wheel } i, \quad x_i = \frac{l - d_i}{2}, \quad M_i = \frac{(l - d_i)^2}{4l} W_T - \sum_{j=1}^{i-1} W_j a_{ji}$$

Note for wheel 1:  $\Sigma W_j a_{ji} = 0$

$$W_T = 104.4, \quad W_1 = W_2 = W_3 = W_4 = \frac{104.4}{4} = 26.1 \text{ kips}$$

$$\text{Wheel 1: } d_1 = \frac{476}{2} = 238 \text{ in}, \quad M_1 = \frac{(1200 - 238)^2}{4(1200)} (104.4) = 20128 \text{ kip} \cdot \text{in}$$

$$\text{Wheel 2: } d_2 = 238 - 84 = 154 \text{ in}$$

$$M_2 = \frac{(1200 - 154)^2}{4(1200)}(104.4) - 26.1(84) = 21\,605 \text{ kip} \cdot \text{in} = M_{\max} \quad \text{Ans.}$$

Check if all of the wheels are on the rail.

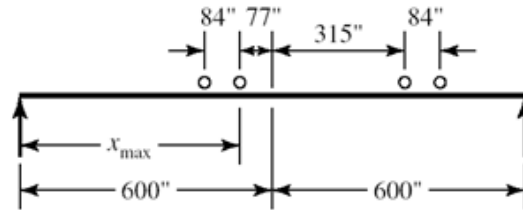

- (b)  $x_{\max} = 600 - 77 = 523 \text{ in} \quad \text{Ans.}$   
 (c) See above sketch.  
 (d) Inner axles

### 3-34

- (a) Let  $a$  = total area of entire envelope  
 Let  $b$  = area of side notch  
 $A = a - 2b = 40(3)(25) - 25(34) = 2150 \text{ mm}^2$   
 $I = I_a - 2I_b = \frac{1}{12}(40)(75)^3 - \frac{1}{12}(34)(25)^3$   
 $I = 1.36(10^6) \text{ mm}^4 \quad \text{Ans.}$

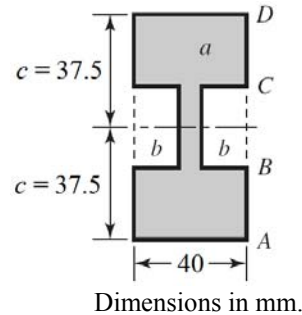

- (b)  
 $A_a = 0.375(1.875) = 0.703\,125 \text{ in}^2$   
 $A_b = 0.375(1.75) = 0.656\,25 \text{ in}^2$   
 $A = 2(0.703\,125) + 0.656\,25 = 2.0625 \text{ in}^2$

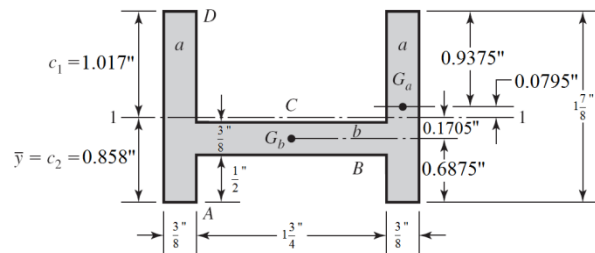

$$\bar{y} = \frac{2(0.703\,125)(0.9375) + 0.656\,25(0.6875)}{2.0625} = 0.858 \text{ in} \quad \text{Ans.}$$

$$I_a = \frac{0.375(1.875)^3}{12} = 0.206 \text{ in}^4$$

$$I_b = \frac{1.75(0.375)^3}{12} = 0.007\,69 \text{ in}^4$$

$$I_1 = 2[0.206 + 0.703\,125(0.0795)^2] + [0.00769 + 0.656\,25(0.1705)^2] = 0.448 \text{ in}^4 \quad \text{Ans.}$$

- (c)  
 Use two negative areas.

$$A_a = 625 \text{ mm}^2, \quad A_b = 5625 \text{ mm}^2, \quad A_c = 10\,000 \text{ mm}^2$$

$$A = 10\,000 - 5625 - 625 = 3750 \text{ mm}^2;$$

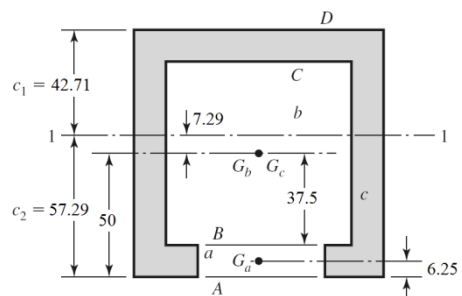



$$\bar{y}_a = 6.25 \text{ mm}, \bar{y}_b = 50 \text{ mm}, \bar{y}_c = 50 \text{ mm}$$

$$\bar{y} = \frac{10\,000(50) - 5625(50) - 625(6.25)}{3750} = 57.29 \text{ mm} \quad \text{Ans.}$$

$$c_1 = 100 - 57.29 = 42.71 \text{ mm} \quad \text{Ans.}$$

$$I_a = \frac{50(12.5)^3}{12} = 8138 \text{ mm}^4$$

$$I_b = \frac{75(75)^3}{12} = 2.637(10^6) \text{ mm}^4$$

$$I_c = \frac{100(100)^3}{12} = 8.333(10^6) \text{ in}^4$$

$$I_1 = [8.333(10^6) + 10\,000(7.29)^2] - [2.637(10^6) + 5625(7.29)^2] - [8138 + 625(57.29 - 6.25)^2]$$

$$I_1 = 4.29(10^6) \text{ in}^4 \quad \text{Ans.}$$

(d)

$$A_a = 4(0.875) = 3.5 \text{ in}^2$$

$$A_b = 2.5(0.875) = 2.1875 \text{ in}^2$$

$$A = A_a + A_b = 5.6875 \text{ in}^2$$

$$\bar{y} = \frac{2.9375(3.5) + 1.25(2.1875)}{5.6875} = 2.288 \text{ in} \quad \text{Ans.}$$

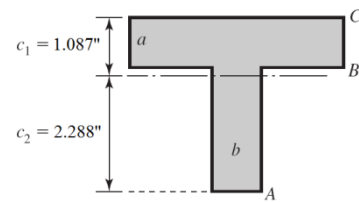

$$I = \frac{1}{12}(4)(0.875)^3 + 3.5(2.9375 - 2.288)^2 + \frac{1}{12}(0.875)(2.5)^3 + 2.1875(2.288 - 1.25)^2$$

$$I = 5.20 \text{ in}^4 \quad \text{Ans.}$$

### 3-35

$$I = \frac{1}{12}(20)(40)^3 = 1.067(10^5) \text{ mm}^4$$

$$A = 20(40) = 800 \text{ mm}^2$$

$M_{\max}$  is at A. At the bottom of the section,

$$\sigma_{\max} = \frac{Mc}{I} = \frac{450\,000(20)}{1.067(10^5)} = 84.3 \text{ MPa} \quad \text{Ans.}$$

Due to V,  $\tau_{\max}$  is between A and B at  $y = 0$ .

$$\tau_{\max} = \frac{3V}{2A} = \frac{3}{2} \left( \frac{3000}{800} \right) = 5.63 \text{ MPa} \quad \text{Ans.}$$

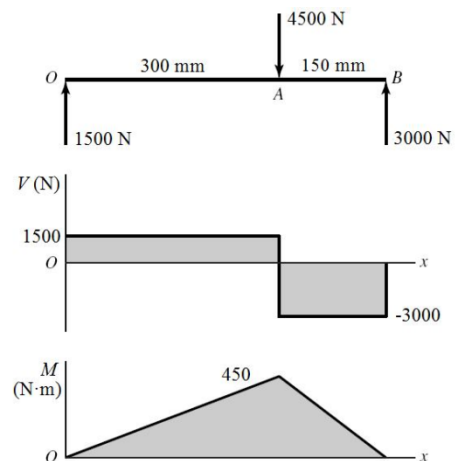

**3-36**

$$I = \frac{1}{12}(1)(2)^3 = 0.6667 \text{ in}^4$$

$$A = 1(2) = 2 \text{ in}^2$$

$$\Sigma M_o = 0$$

$$8R_A - 100(8)(12) = 0$$

$$R_A = 1200 \text{ lbf}$$

$$R_o = 1200 - 100(8) = 400 \text{ lbf}$$

$M_{\max}$  is at  $A$ . At the top of the beam,

$$\sigma_{\max} = \frac{Mc}{I} = \frac{3200(0.5)}{0.6667} = 2400 \text{ psi} \quad \text{Ans.}$$

Due to  $V$ ,  $\tau_{\max}$  is at  $A$ , at  $y = 0$ .

$$\tau_{\max} = \frac{3V}{2A} = \frac{3}{2} \left( \frac{800}{2} \right) = 600 \text{ psi} \quad \text{Ans.}$$

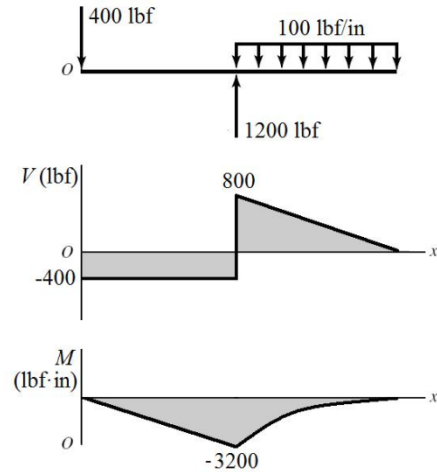

**3-37**

$$I = \frac{1}{12}(0.75)(2)^3 = 0.5 \text{ in}^4$$

$$A = (0.75)(2) = 1.5 \text{ in}^2$$

$$\Sigma M_A = 0$$

$$15R_B - 1000(20) = 0$$

$$R_B = 1333.3 \text{ lbf}$$

$$R_A = 3000 - 1333.3 + 1000 = 2666.7 \text{ lbf}$$

$M_{\max}$  is at  $B$ . At the top of the beam,

$$\sigma_{\max} = \frac{Mc}{I} = \frac{5000(1)}{0.5} = 10000 \text{ psi} \quad \text{Ans.}$$

Due to  $V$ ,  $\tau_{\max}$  is between  $B$  and  $C$  at  $y = 0$ .

$$\tau_{\max} = \frac{3V}{2A} = \frac{3}{2} \left( \frac{1000}{1.5} \right) = 1000 \text{ psi} \quad \text{Ans.}$$

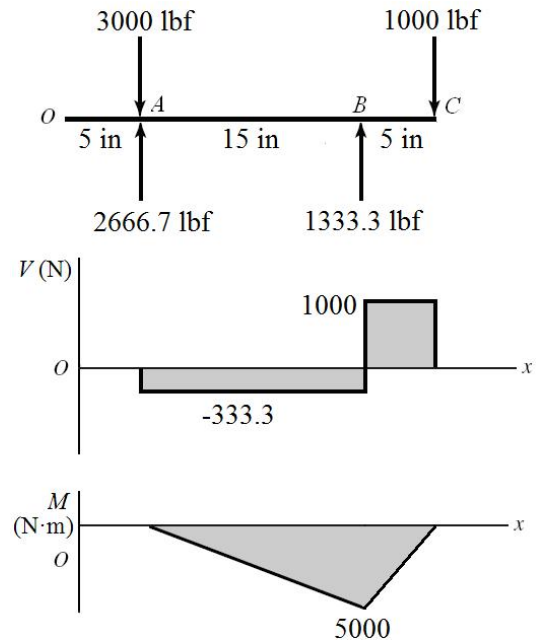

3-38

$$I = \frac{\pi d^4}{64} = \frac{\pi(50)^4}{64} = 306.796(10^3) \text{ mm}^4$$

$$A = \frac{\pi d^2}{4} = \frac{\pi(50)^2}{4} = 1963 \text{ mm}^2$$

$$\Sigma M_B = 0$$

$$6(300)(150) - 200R_A = 0$$

$$R_A = 1350 \text{ kN}$$

$$R_B = 6(300) - 1350 = 450 \text{ kN}$$

$M_{\max}$  is at A. At the top,

Due to  $V$ ,  $\tau_{\max}$  is at A, at  $y = 0$ .

$$\tau_{\max} = \frac{4V}{3A} = \frac{4}{3} \left( \frac{750}{1963} \right) = 0.509 \text{ kN/mm}^2 = 509 \text{ MPa} \quad \text{Ans.}$$

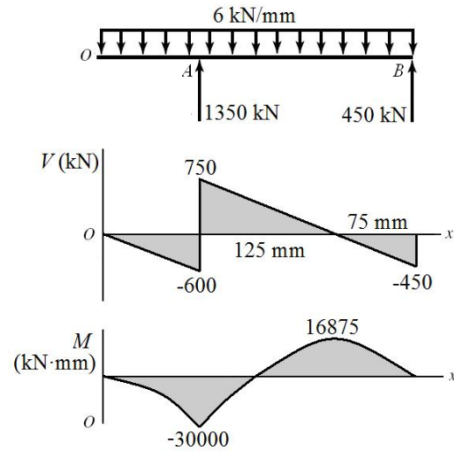

$$\sigma_{\max} = \frac{Mc}{I}$$

3-39

$$M_{\max} = \frac{wl^2}{8} \Rightarrow \sigma_{\max} = \frac{wl^2 c}{8I} \Rightarrow w = \frac{8\sigma_{\max} I}{cl^2}$$

(a)  $l = 48 \text{ in}$ ; Table A-8,  $I = 0.537 \text{ in}^4$

$$w = \frac{8(12)(10^3)(0.537)}{1(48^2)} = 22.38 \text{ lbf/in} \quad \text{Ans.}$$

(b)  $l = 60 \text{ in}$ ,  $I = (1/12)(2)(3^3) - (1/12)(1.625)(2.625^3) = 2.051 \text{ in}^4$

$$w = \frac{8(12)(10^3)(2.051)}{(1.5)(60^2)} = 36.5 \text{ lbf/in} \quad \text{Ans.}$$

(c)  $l = 60 \text{ in}$ ; Table A-6,  $I = 2(0.703) = 1.406 \text{ in}^4$

$y = 0.717 \text{ in}$ ,  $c_{\max} = 1.783 \text{ in}$

$$w = \frac{8(12)(10^3)(1.406)}{1.783(60^2)} = 21.0 \text{ lbf/in} \quad \text{Ans.}$$

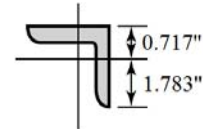

(d)  $l = 60 \text{ in}$ , Table A-7,  $I = 2.07 \text{ in}^4$

$$w = \frac{8(12)(10^3)(2.07)}{1.5(60^2)} = 36.8 \text{ lbf/in} \quad \text{Ans.}$$

**3-40**

$$I = \frac{\pi}{64}(0.5^4) = 3.068(10^{-3}) \text{ in}^4, \quad A = \frac{\pi}{4}(0.5^2) = 0.1963 \text{ in}^2$$

Model

$$M = \frac{500(0.5)}{2} + \frac{500(0.75/2)}{2} = 218.75 \text{ lbf} \cdot \text{in}$$

$$(c) \quad \sigma = \frac{Mc}{I} = \frac{218.75(0.25)}{3.068(10^{-3})}$$

$$\sigma = 17\,825 \text{ psi} = 17.8 \text{ kpsi} \quad \text{Ans.}$$

$$\tau_{\max} = \frac{4V}{3A} = \frac{4 \cdot 500}{3 \cdot 0.1963} = 3400 \text{ psi} = 3.4 \text{ kpsi} \quad \text{Ans.}$$

Model (d)

$$M = 500(0.625) = 312.5 \text{ lbf} \cdot \text{in}$$

$$\sigma = \frac{Mc}{I} = \frac{312.5(0.25)}{3.068(10^{-3})}$$

$$\sigma = 25\,464 \text{ psi} = 25.5 \text{ kpsi} \quad \text{Ans.}$$

$$\tau_{\max} = \frac{4V}{3A} = \frac{4 \cdot 500}{3 \cdot 0.1963} = 3400 \text{ psi} = 3.4 \text{ kpsi} \quad \text{Ans.}$$

Model

$$M = 500(0.4375) = 218.75 \text{ lbf} \cdot \text{in}$$

$$\sigma = \frac{Mc}{I} = \frac{218.75(0.25)}{3.068(10^{-3})}$$

$$(e) \quad \sigma = 17\,825 \text{ psi} = 17.8 \text{ kpsi} \quad \text{Ans.}$$

$$\tau_{\max} = \frac{4V}{3A} = \frac{4 \cdot 500}{3 \cdot 0.1963} = 3400 \text{ psi} = 3.4 \text{ kpsi} \quad \text{Ans.}$$

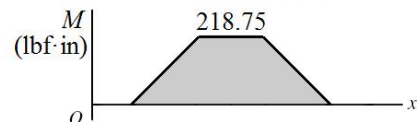
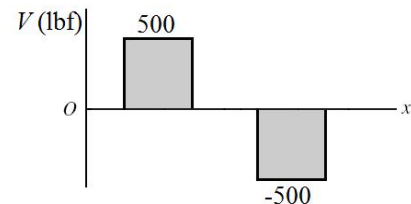
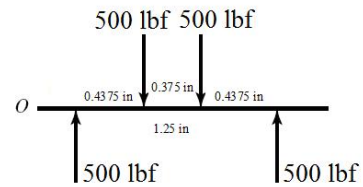
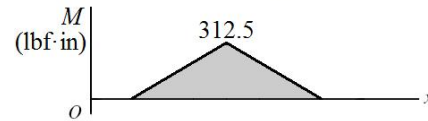
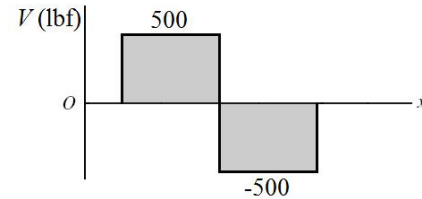
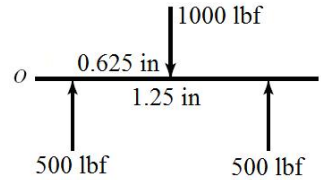
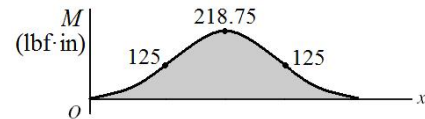
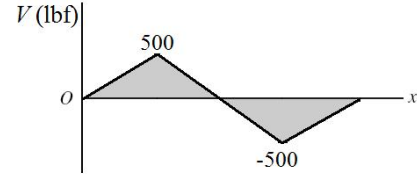
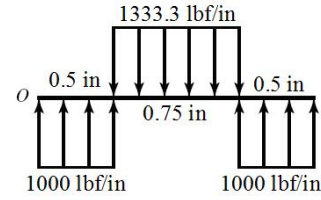

**3-41**

$$I = \frac{\pi}{64}(12^4) = 1018 \text{ mm}^4, \quad A = \frac{\pi}{4}(12^2) = 113.1 \text{ mm}^2$$

Model (c)

$$M = \frac{2000(6)}{2} + \frac{2000(9)}{2} = 15\,000 \text{ N}\cdot\text{mm}$$

$$\sigma = \frac{Mc}{I} = \frac{15\,000(6)}{1018}$$

$$\sigma = 88.4 \text{ N/mm}^2 = 88.4 \text{ MPa} \quad \text{Ans.}$$

$$\tau_{\max} = \frac{4V}{3A} = \frac{4}{3} \left( \frac{2000}{113.1} \right) = 23.6 \text{ N/mm}^2 = 23.6 \text{ MPa} \quad \text{Ans.}$$

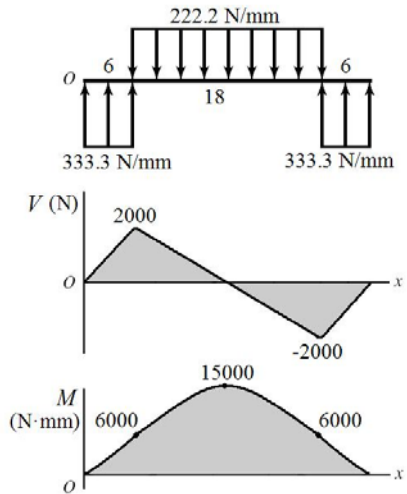

Model (d)

$$M = 2000(12) = 24\,000 \text{ N}\cdot\text{mm}$$

$$\sigma = \frac{Mc}{I} = \frac{24\,000(6)}{1018}$$

$$\sigma = 141.5 \text{ N/mm}^2 = 141.5 \text{ MPa} \quad \text{Ans.}$$

$$\tau_{\max} = \frac{4V}{3A} = \frac{4}{3} \left( \frac{2000}{113.1} \right) = 23.6 \text{ N/mm}^2 = 23.6 \text{ MPa} \quad \text{Ans.}$$

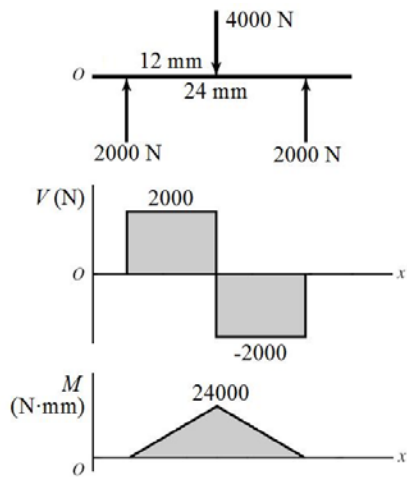

Model (e)

$$M = 2000(7.5) = 15\,000 \text{ N}\cdot\text{mm}$$

$$\sigma = \frac{Mc}{I} = \frac{15\,000(6)}{1018}$$

$$\sigma = 88.4 \text{ N/mm}^2 = 88.4 \text{ MPa} \quad \text{Ans.}$$

$$\tau_{\max} = \frac{4V}{3A} = \frac{4}{3} \left( \frac{2000}{113.1} \right) = 23.6 \text{ N/mm}^2 = 23.6 \text{ MPa} \quad \text{Ans.}$$

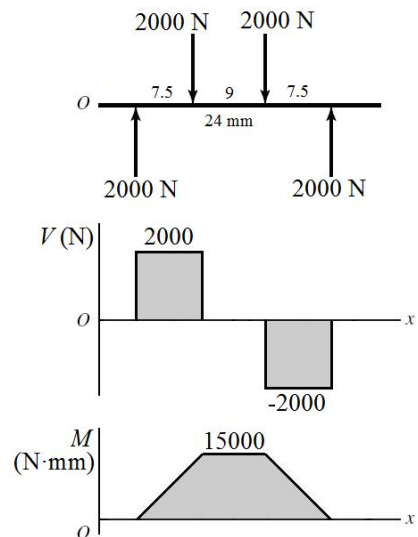

---

3-42 (a)  $\sigma = \frac{Mc}{I} = \frac{M(d/2)}{\pi d^4 / 64} = \frac{32M}{\pi d^3}$

$$d = \sqrt[3]{\frac{32M}{\pi\sigma}} = \sqrt[3]{\frac{32(218.75)}{\pi(30\,000)}} = 0.420 \text{ in } \textit{Ans.}$$

$$(b) \tau = \frac{V}{A} = \frac{V}{\pi d^2 / 4}$$

$$d = \sqrt{\frac{4V}{\pi\tau}} = \sqrt{\frac{4(500)}{\pi(15\,000)}} = 0.206 \text{ in } \textit{Ans.}$$

$$(c) \tau = \frac{4V}{3A} = \frac{4}{3} \frac{V}{(\pi d^2 / 4)}$$

$$d = \sqrt{\frac{4}{3} \frac{4V}{\pi\tau}} = \sqrt{\frac{4}{3} \frac{4(500)}{\pi(15\,000)}} = 0.238 \text{ in } \textit{Ans.}$$

3-43

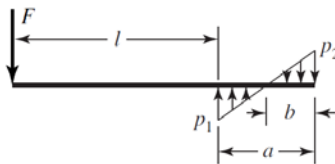

$$q = -F\langle x \rangle^{-1} + p_1\langle x-l \rangle^0 - \frac{p_1+p_2}{a}\langle x-l \rangle^1 + \text{terms for } x > l+a$$

$$V = -Fx + p_1\langle x-l \rangle^1 - \frac{p_1+p_2}{2a}\langle x-l \rangle^2 + \text{terms for } x > l+a$$

$$M = -Fx^2 + \frac{p_1}{2}\langle x-l \rangle^2 - \frac{p_1+p_2}{6a}\langle x-l \rangle^3 + \text{terms for } x > l+a$$

At  $x = (l+a)^+$ ,  $V = M = 0$ , terms for  $x > l+a = 0$

$$-F + p_1 a - \frac{p_1+p_2}{2a} a^2 = 0 \quad \Rightarrow \quad p_1 - p_2 = \frac{2F}{a} \quad (1)$$

$$-F(l+a) + \frac{p_1 a^2}{2} - \frac{p_1+p_2}{6a} a^3 = 0 \quad \Rightarrow \quad 2p_1 - p_2 = \frac{6F(l+a)}{a^2} \quad (2)$$

From (1) and (2) 
$$p_1 = \frac{2F}{a^2}(3l+2a), \quad p_2 = \frac{2F}{a^2}(3l+a) \quad (3)$$

From similar triangles 
$$\frac{b}{p_2} = \frac{a}{p_1+p_2} \quad \Rightarrow \quad b = \frac{ap_2}{p_1+p_2} \quad (4)$$

$M_{\max}$  occurs where  $V = 0$

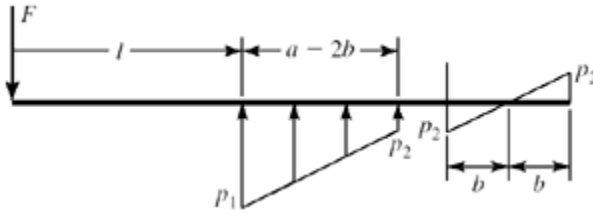

$$x_{\max} = l + a - 2b$$

$$M_{\max} = -Fl + a - 2b + \frac{p_1}{2}(a - 2b)^2 - \frac{p_1 + p_2}{6a}(a - 2b)^3$$

$$= -Fl - F(a - 2b) + \frac{p_1}{2}(a - 2b)^2 - \frac{p_1 + p_2}{6a}(a - 2b)^3$$

Normally  $M_{\max} = -Fl$

The fractional increase in the magnitude is

$$\Delta = \frac{F(a - 2b) - (p_1/2)(a - 2b)^2 + [(p_1 + p_2)/6a](a - 2b)^3}{Fl} \quad (5)$$

For example, consider  $F = 1500$  lbf,  $a = 1.2$  in,  $l = 1.5$  in

$$(3) \quad p_1 = \frac{2(1500)}{1.2^2} [3(1.5) + 2(1.2)] = 14\,375 \text{ lbf/in}$$

$$p_2 = \frac{2(1500)}{1.2^2} [3(1.5) + 1.2] = 11\,875 \text{ lbf/in}$$

$$(4) \quad b = 1.2(11\,875)/(14\,375 + 11\,875) = 0.5429 \text{ in}$$

Substituting into (5) yields

$$\Delta = 0.036\,89 \text{ or } 3.7\% \text{ higher than } -Fl$$

3-44

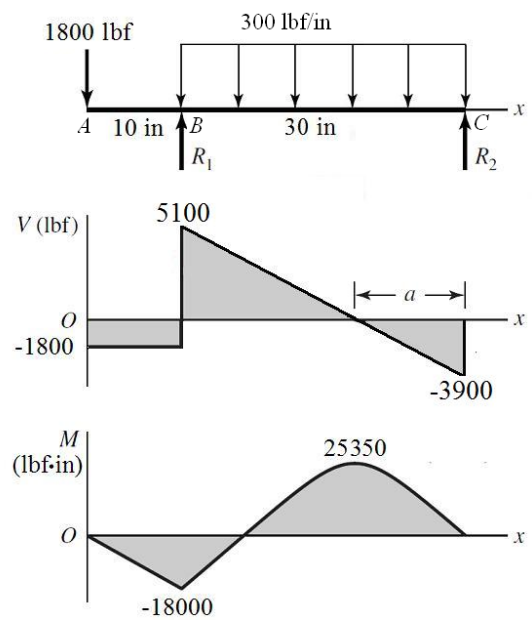

$$R_1 = \frac{300(30)}{2} + \frac{40}{30}1800 = 6900 \text{ lbf}$$

$$R_2 = \frac{300(30)}{2} - \frac{10}{30}1800 = 3900 \text{ lbf}$$

$$a = \frac{3900}{300} = 13 \text{ in}$$

$$M_B = -1800(10) = -18\,000 \text{ lbf}\cdot\text{in}$$

$$M_{x=27 \text{ in}} = (1/2)3900(13) = 25\,350 \text{ lbf}\cdot\text{in}$$

$$\bar{y} = \frac{0.5(3) + 2.5(3)}{6} = 1.5 \text{ in}$$

$$I_1 = \frac{1}{12}(3)(1^3) = 0.25 \text{ in}^4$$

$$I_2 = \frac{1}{12}(1)(3^3) = 2.25 \text{ in}^4$$

Applying the parallel-axis theorem,

$$I_z = [0.25 + 3(1.5 - 0.5)^2] + [2.25 + 3(2.5 - 1.5)^2] = 8.5 \text{ in}^4$$

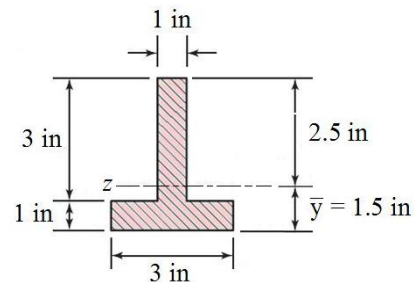

$$\text{At } x = 10 \text{ in, } y = -1.5 \text{ in, } \sigma_x = -\frac{-18000(-1.5)}{8.5} = -3176 \text{ psi}$$

$$\text{At } x = 10 \text{ in, } y = 2.5 \text{ in, } \sigma_x = -\frac{-18000(2.5)}{8.5} = 5294 \text{ psi}$$

(a)

$$\text{At } x = 27 \text{ in, } y = -1.5 \text{ in, } \sigma_x = -\frac{25350(-1.5)}{8.5} = 4474 \text{ psi}$$

$$\text{At } x = 27 \text{ in, } y = 2.5 \text{ in, } \sigma_x = -\frac{25350(2.5)}{8.5} = -7456 \text{ psi}$$

Max tension = 5294 psi      *Ans.*

Max compression = -7456 psi      *Ans.*

(b) The maximum shear stress due to  $V$  is at  $B$ , at the neutral axis.

$$V_{\max} = 5100 \text{ lbf}$$

$$Q = \bar{y}'A' = 1.25(2.5)(1) = 3.125 \text{ in}^3$$

$$(\tau_{\max})_V = \frac{VQ}{Ib} = \frac{5100(3.125)}{8.5(1)} = 1875 \text{ psi} \quad \text{Ans.}$$

(c) There are three potentially critical locations for the maximum shear stress, all at  $x = 27 \text{ in}$ : (i) at the top where the bending stress is maximum, (ii) at the neutral axis where



the transverse shear is maximum, or (iii) in the web just above the flange where bending stress and shear stress are in their largest combination.

For (i):

The maximum bending stress was previously found to be  $-7456$  psi, and the shear stress is zero. From Mohr's circle,

$$\tau_{\max} = \frac{|\sigma_{\max}|}{2} = \frac{7456}{2} = 3728 \text{ psi}$$

For (ii):

The bending stress is zero, and the transverse shear stress was found previously to be  $1875$  psi. Thus,  $\tau_{\max} = 1875$  psi.

For (iii):

The bending stress at  $y = -0.5$  in is

$$\sigma_x = -\frac{-18000(-0.5)}{8.5} = -1059 \text{ psi}$$

The transverse shear stress is

$$Q = \bar{y}'A' = (1)(3)(1) = 3.0 \text{ in}^3$$

$$\tau = \frac{VQ}{Ib} = \frac{5100(3.0)}{8.5(1)} = 1800 \text{ psi}$$

From Mohr's circle,

$$\tau_{\max} = \sqrt{\left(\frac{-1059}{2}\right)^2 + 1800^2} = 1876 \text{ psi}$$

The critical location is at  $x = 27$  in, at the top surface, where  $\tau_{\max} = 3728$  psi. *Ans.*

**3-45** (a)  $L = 10$  in. Element *A*:

$$\sigma_A = -\frac{My}{I} = -\frac{(1000)(10)(0.5)}{(\pi/64)(1)^4} (10^{-3}) = 101.9 \text{ kpsi}$$

$$\tau_A = \frac{VQ}{Ib}, \quad Q = 0 \Rightarrow \tau_A = 0$$

$$\tau_{\max} = \sqrt{\left(\frac{\sigma_A}{2}\right)^2 + \tau_A^2} = \sqrt{\left(\frac{101.9}{2}\right)^2 + (0)^2} = 50.9 \text{ kpsi} \quad \text{Ans.}$$

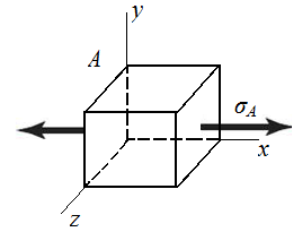

Element *B*:

$$\sigma_B = -\frac{My}{I}, \quad y = 0 \Rightarrow \sigma_B = 0$$

$$Q = \bar{y}'A' = \left(\frac{4r}{3\pi}\right)\left(\frac{\pi r^2}{2}\right) = \frac{4r^3}{6} = \frac{4(0.5)^3}{6} = 1/12 \text{ in}^3$$

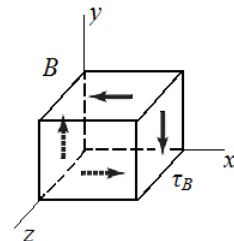

$$\tau_B = \frac{VQ}{Ib} = \frac{(1000)(1/12)}{(\pi/64)(1)^4(1)}(10^{-3}) = 1.698 \text{ kpsi}$$

$$\tau_{\max} = \sqrt{\left(\frac{0}{2}\right)^2 + 1.698^2} = 1.698 \text{ kpsi} \quad \text{Ans.}$$

Element C:

$$\sigma_C = -\frac{My}{I} = -\frac{(1000)(10)(0.25)}{(\pi/64)(1)^4}(10^{-3}) = 50.93 \text{ kpsi}$$

$$\begin{aligned} Q &= \int_{y_1}^r y dA = \int_{y_1}^r y(2x) dy = \int_{y_1}^r y(2\sqrt{r^2 - y^2}) dy \\ &= -\frac{2}{3}(r^2 - y^2)^{3/2} \Big|_{y_1}^r = -\frac{2}{3}[(r^2 - r^2)^{3/2} - (r^2 - y_1^2)^{3/2}] \\ &= \frac{2}{3}(r^2 - y_1^2)^{3/2} \end{aligned}$$

For C,  $y_1 = r/2 = 0.25$  in

$$Q = \frac{2}{3}(0.5^2 - 0.25^2)^{3/2} = 0.05413 \text{ in}^3$$

$$b = 2x = 2\sqrt{r^2 - y_1^2} = 2\sqrt{0.5^2 - 0.25^2} = 0.866 \text{ in}$$

$$\tau_C = \frac{VQ}{Ib} = \frac{(1000)(0.05413)}{(\pi/64)(1)^4(0.866)}(10^{-3}) = 1.273 \text{ kpsi}$$

$$\tau_{\max} = \sqrt{\left(\frac{50.93}{2}\right)^2 + (1.273)^2} = 25.50 \text{ kpsi} \quad \text{Ans.}$$

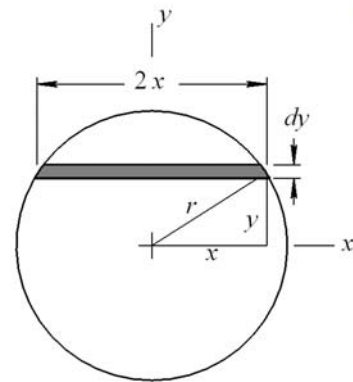
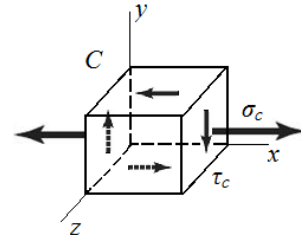

(b) Neglecting transverse shear stress:

Element A: Since the transverse shear stress at point A is zero, there is no change.

$$\tau_{\max} = 50.9 \text{ kpsi} \quad \text{Ans.}$$

$$\% \text{ error} = 0\% \quad \text{Ans.}$$

Element B: Since the only stress at point B is transverse shear stress, neglecting the transverse shear stress ignores the entire stress.

$$\tau_{\max} = \sqrt{\left(\frac{0}{2}\right)^2} = 0 \text{ psi} \quad \text{Ans.}$$

$$\% \text{ error} = \left(\frac{1.698 - 0}{1.698}\right) * (100) = 100\% \quad \text{Ans.}$$

Element C:

$$\tau_{\max} = \sqrt{\left(\frac{50.93}{2}\right)^2} = 25.47 \text{ kpsi} \quad \text{Ans.}$$

$$\% \text{ error} = \left(\frac{25.50 - 25.47}{25.50}\right) * (100) = 0.12\% \quad \text{Ans.}$$

(c) Repeating the process with different beam lengths produces the results in the table.

|                  | Bending stress, $\sigma$ (kpsi) | Transverse shear stress, $\tau$ (kpsi) | Max shear stress, $\tau_{\max}$ (kpsi) | Max shear stress, neglecting $\tau$ , $\tau_{\max}$ (kpsi) | % error |
|------------------|---------------------------------|--|--|--|---------|
| <b>L = 10 in</b> |                                 |  |  |  |         |
| A                | 102                             | 0                                      | 50.9                                   | 50.9   | 0       |
| B                | 0                               | 1.70                                   | 1.70                                   | 0  | 100     |
| C                | 50.9                            | 1.27                                   | 25.50                                  | 25.47  | 0.12    |
| <b>L = 4 in</b>  |                                 |  |  |  |         |
| A                | 40.7                            | 0                                      | 20.4                                   | 20.4   | 0       |
| B                | 0                               | 1.70                                   | 1.70                                   | 0  | 100     |
| C                | 20.4                            | 1.27                                   | 10.26                                  | 10.19  | 0.77    |
| <b>L = 1 in</b>  |                                 |  |  |  |         |
| A                | 10.2                            | 0                                      | 5.09                                   | 5.09   | 0       |
| B                | 0                               | 1.70                                   | 1.70                                   | 0  | 100     |
| C                | 5.09                            | 1.27                                   | 2.85                                   | 2.55   | 10.6    |
| <b>L = 0.1in</b> |                                 |  |  |  |         |
| A                | 1.02                            | 0                                      | 0.509                                  | 0.509  | 0       |
| B                | 0                               | 1.70                                   | 1.70                                   | 0  | 100     |
| C                | 0.509                           | 1.27                                   | 1.30                                   | 0.255  | 80.4    |

Discussion:

The transverse shear stress is only significant in determining the critical stress element as the length of the cantilever beam becomes smaller. As this length decreases, bending stress reduces greatly and transverse shear stress stays the same. This causes the critical element location to go from being at point A, on the surface, to point B, in the center. The maximum shear stress is on the outer surface at point A for all cases except  $L = 0.1$  in, where it is at point B at the center. When the critical stress element is at point A, there is no error from neglecting transverse shear stress, since it is zero at that location.

Neglecting the transverse shear stress has extreme significance at the stress element at the center at point B, but that location is probably only of practical significance for very short beam lengths.

3-46

$$R_1 = \frac{c}{l} F$$

$$M = \frac{c}{l} Fx \quad 0 \leq x \leq a$$

$$\sigma = \frac{6M}{bh^2} = \frac{6(c/l)Fx}{bh^2}$$

$$h = \sqrt{\frac{6Fc x}{lb\sigma_{\max}}} \quad 0 \leq x \leq a \quad \text{Ans.}$$

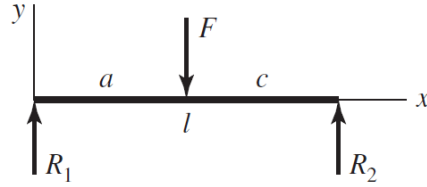

3-47

From Problem 3-46,  $R_1 = \frac{c}{l} F = V$ ,  $0 \leq x \leq a$

$$\tau_{\max} = \frac{3V}{2bh} = \frac{3(c/l)F}{2bh} \Rightarrow h = \frac{3Fc}{2lb\tau_{\max}} \quad \text{Ans.}$$

From Problem 3-46,  $h(x) = \sqrt{\frac{6Fc x}{lb\sigma_{\max}}}$ .

Sub in  $x = e$  and equate to  $h$  above.

$$\frac{3Fc}{2lb\tau_{\max}} = \sqrt{\frac{6Fce}{lb\sigma_{\max}}}$$

$$e = \frac{3Fc\sigma_{\max}}{8lb\tau_{\max}^2} \quad \text{Ans.}$$



3-48 (a)

x-z plane

$$\Sigma M_O = 0 = 1.5(0.5) + 2(1.5)\sin(30^\circ)(2.25) - R_{2z}(3)$$

$$R_{2z} = 1.375 \text{ kN} \quad \text{Ans.}$$

$$\Sigma F_z = 0 = R_{1z} - 1.5 - 2(1.5)\sin(30^\circ) + 1.375$$

$$R_{1z} = 1.625 \text{ kN} \quad \text{Ans.}$$

x-y plane

$$\Sigma M_O = 0 = -2(1.5)\cos(30^\circ)(2.25) + R_{2y}(3)$$

$$R_{2y} = 1.949 \text{ kN} \quad \text{Ans.}$$

$$\Sigma F_y = 0 = R_{1y} - 2(1.5)\cos(30^\circ) + 1.949$$

$$R_{1y} = 0.6491 \text{ kN} \quad \text{Ans.}$$

(b)

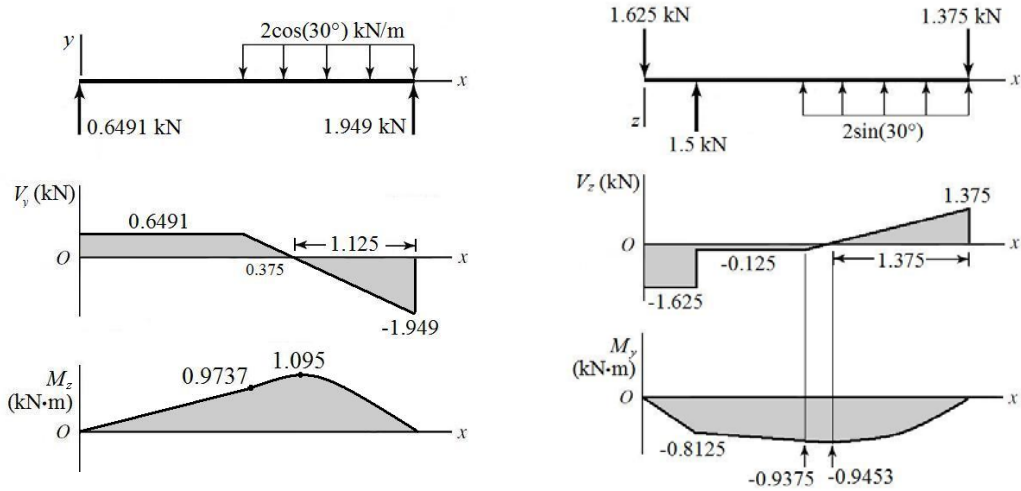

(c) The transverse shear and bending moments for most points of interest can readily be taken straight from the diagrams. For  $1.5 < x < 3$ , the bending moment equations are parabolic, and are obtained by integrating the linear expressions for shear. For convenience, use a coordinate shift of  $x' = x - 1.5$ . Then, for  $0 < x' < 1.5$ ,

$$V_z = x' - 0.125$$

$$M_y = \int V_z dx' = \frac{(x')^2}{2} - 0.125x' + C$$

$$\text{At } x' = 0, M_y = C = -0.9375 \Rightarrow M_y = 0.5(x')^2 - 0.125x' + 0.9375$$

$$V_y = -\frac{1.949}{1.125}x' + 0.6491 = -1.732x' + 0.6491$$

$$M_z = \frac{-1.732}{2}(x')^2 + 0.6491x' + C$$

$$\text{At } x' = 0, M_z = C = 0.9737 \Rightarrow M_z = -0.8662(x')^2 - 0.125x' - 0.9375$$

By programming these bending moment equations, we can find  $M_y$ ,  $M_z$ , and their vector combination at any point along the beam. The maximum combined bending moment is found to be at  $x = 1.79$  m, where  $M = 1.433$  kN·m. The table below shows values at key locations on the shear and bending moment diagrams.

| $x$ (m)          | $V_z$ (kN) | $V_y$ (kN) | $V$ (kN) | $M_y$ (kN·m) | $M_z$ (kN·m) | $M$ (kN·m) |
|------------------|------------|------------|----------|--------------|--------------|------------|
| 0                | -1.625     | 0.6491     | 1.750    | 0            | 0            | 0          |
| 0.5 <sup>-</sup> | -1.625     | 0.6491     | 1.750    | -0.8125      | 0.3246       | 0.8749     |
| 1.5              | -0.1250    | 0.6491     | 0.6610   | 0.9375       | 0.9737       | 1.352      |
| 1.625            | 0          | 0.4327     | 0.4327   | -0.9453      | 1.041        | 1.406      |
| 1.875            | 0.2500     | 0          | 0.2500   | -0.9141      | 1.095        | 1.427      |
| 3 <sup>-</sup>   | 1.375      | -1.949     | 2.385    | 0            | 0            | 0          |

(d) The bending stress is obtained from Eq. (3-27),

$$\sigma_x = \frac{-M_z y_A}{I_z} + \frac{M_y z_A}{I_y}$$

The maximum tensile bending stress will be at point  $A$  in the cross section of Prob. 3-34 (a), where distances from the neutral axes for both bending moments will be maximum.

At  $A$ , for  $M_z, y_A = -37.5$  mm, and for  $M_y, z_A = -20$  mm.

$$I_z = \frac{40(75)^3}{12} - \frac{34(25)^3}{12} = 1.36(10^6) \text{ mm}^4 = 1.36(10^{-6}) \text{ m}^4$$

$$I_y = 2 \left[ \frac{25(40)^3}{12} \right] + \frac{25(6)^3}{12} = 2.67(10^5) \text{ mm}^4 = 2.67(10^{-7}) \text{ m}^4$$

It is apparent the maximum bending moment, and thus the maximum stress, will be in the parabolic section of the bending moment diagrams. Programming Eq. (3-27) with the bending moment equations previously derived, the maximum tensile bending stress is found at  $x = 1.77$  m, where  $M_y = -0.9408$  kN·m,  $M_z = 1.075$  kN·m, and  $\sigma_x = 100.1$  MPa.  
*Ans.*

### 3-49

(a)  $x$ - $z$  plane

$$\Sigma M_O = 0 = \frac{3}{5}(1000)(4) - \frac{600}{\sqrt{2}}(10) + M_{Oy}$$

$$M_{Oy} = 1842.6 \text{ lbf} \cdot \text{in} \quad \text{Ans.}$$

$$\Sigma F_z = 0 = R_{Oz} - \frac{3}{5}(1000) + \frac{600}{\sqrt{2}}$$

$$R_{Oz} = 175.7 \text{ lbf} \quad \text{Ans.}$$

$x$ - $y$  plane

$$\Sigma M_O = 0 = -\frac{4}{5}(1000)(4) - \frac{600}{\sqrt{2}}(10) + M_{Oz}$$

$$M_{Oz} = 7442.5 \text{ lbf} \cdot \text{in} \quad \text{Ans.}$$

$$\Sigma F_y = 0 = R_{Oy} - \frac{4}{5}(1000) - \frac{600}{\sqrt{2}}$$

$$R_{Oy} = 1224.3 \text{ lbf} \quad \text{Ans.}$$

(b)

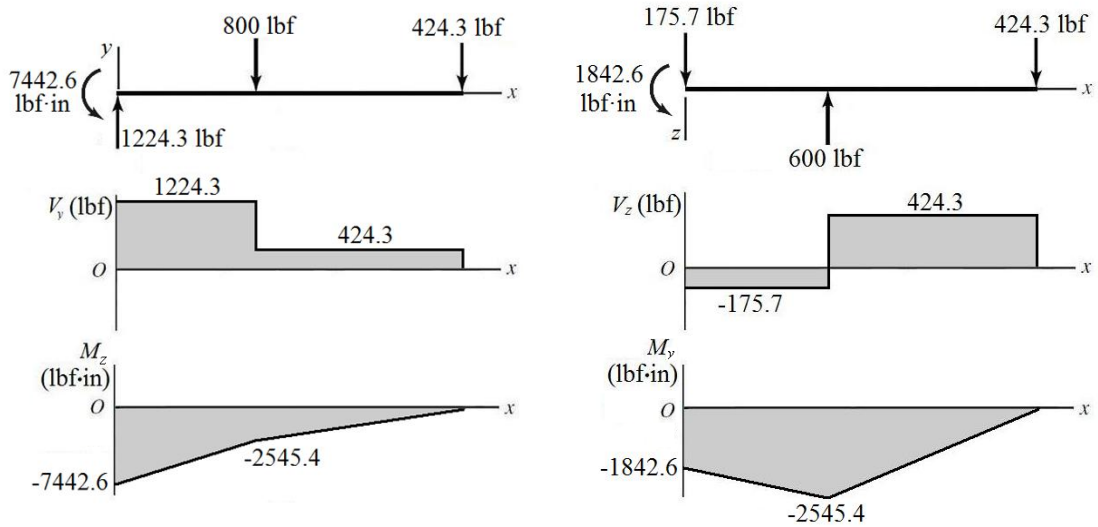

(c)

$$V(x) = [V_y(x)^2 + V_z(x)^2]^{1/2}$$

$$M(x) = [M_y(x)^2 + M_z(x)^2]^{1/2}$$

| $x$ (m)         | $V_z$ (kN) | $V_y$ (kN) | $V$ (kN) | $M_y$ (kN·m) | $M_z$ (kN·m) | $M$ (kN·m) |
|-----------------|------------|------------|----------|--------------|--------------|------------|
| 0               | -175.7     | 1224.3     | 1237     | -1842.6      | -7442.6      | 7667       |
| 4 <sup>-</sup>  | -175.7     | 1224.3     | 1237     | -2545.4      | -2545.4      | 3600       |
| 10 <sup>-</sup> | 424.3      | 424.3      | 600      | 0            | 0            | 0          |

(d) The maximum tensile bending stress will be at the outer corner of the cross section in the positive  $y$ , negative  $z$  quadrant, where  $y = 1.5$  in and  $z = -1$  in.

$$I_z = \frac{2(3)^3}{12} - \frac{(1.625)(2.625)^3}{12} = 2.051 \text{ in}^4$$

$$I_y = \frac{3(2)^3}{12} - \frac{(2.625)(1.625)^3}{12} = 1.601 \text{ in}^4$$

At  $x = 0$ , using Eq. (3-27),

$$\sigma_x = -\frac{M_z y}{I_z} + \frac{M_y z}{I_y}$$

$$\sigma_x = -\frac{(-7442.6)(1.5)}{2.051} + \frac{(-1842.6)(-1)}{1.601} = 6594 \text{ psi}$$

Check at  $x = 4$  in,

$$\sigma_x = -\frac{(-2545.4)(1.5)}{2.051} + \frac{(-2545.4)(-1)}{1.601} = 2706 \text{ psi}$$

The critical location is at  $x = 0$ , where  $\sigma_x = 6594$  psi. *Ans.*

**3-50** The area within the wall median line,  $A_m$ , is

Square:  $A_m = (b-t)^2$ . From Eq. (3-45)

$$T_{sq} = 2A_m t \tau_{all} = 2(b-t)^2 t \tau_{all}$$

Round:  $A_m = \pi(b-t)^2 / 4$

$$T_{rd} = 2\pi(b-t)^2 t \tau_{all} / 4$$

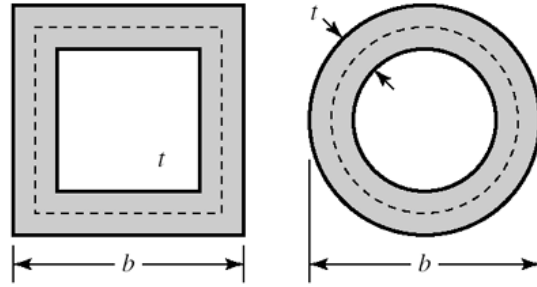

Ratio of Torques

$$\frac{T_{sq}}{T_{rd}} = \frac{2(b-t)^2 t \tau_{all}}{\pi(b-t)^2 t \tau_{all} / 2} = \frac{4}{\pi} = 1.27$$

Twist per unit length from Eq. (3-46) is

$$\theta_1 = \frac{TL_m}{4GA_m^2 t} = \frac{2A_m t \tau_{all} L_m}{4GA_m^2 t} = \frac{\tau_{all} L_m}{2G A_m} = C \frac{L_m}{A_m}$$

Square:

$$\theta_{sq} = C \frac{4(b-t)}{(b-t)^2}$$

Round:

$$\theta_{rd} = C \frac{\pi(b-t)}{\pi(b-t)^2 / 4} = C \frac{4(b-t)}{(b-t)^2}$$

Ratio equals 1. Twists are the same.

**3-51**

(a) The area enclosed by the section median line is  $A_m = (1 - 0.0625)^2 = 0.8789 \text{ in}^2$  and the length of the section median line is  $L_m = 4(1 - 0.0625) = 3.75 \text{ in}$ . From Eq. (3-45),

$$T = 2A_m t \tau = 2(0.8789)(0.0625)(12\ 000) = 1318 \text{ lbf} \cdot \text{in} \quad \text{Ans.}$$

From Eq. (3-46),

$$\theta = \theta_1 l = \frac{TL_m l}{4GA_m^2 t} = \frac{(1318)(3.75)(36)}{4(11.5)(10^6)(0.8789)^2(0.0625)} = 0.0801 \text{ rad} = 4.59^\circ \quad \text{Ans.}$$

(b) The radius at the median line is  $r_m = 0.125 + (0.5)(0.0625) = 0.15625 \text{ in}$ . The area enclosed by the section median line is  $A_m = (1 - 0.0625)^2 - 4(0.15625)^2 + 4(\pi/4)(0.15625)^2 = 0.8579 \text{ in}^2$ . The length of the section median line is  $L_m = 4[1 - 0.0625 - 2(0.15625)] + 2\pi(0.15625) = 3.482 \text{ in}$ .



From Eq. (3-45),

$$T = 2A_m t \tau = 2(0.8579)(0.0625)(12\,000) = 1287 \text{ lbf} \cdot \text{in} \quad \text{Ans.}$$

From Eq. (3-46),

$$\theta = \theta_1 l = \frac{TL_m l}{4GA_m^2 t} = \frac{(1287)(3.482)(36)}{4(11.5)(10^6)(0.8579)^2(0.0625)} = 0.0762 \text{ rad} = 4.37^\circ \quad \text{Ans.}$$

### 3-52

$$\theta_1 = \frac{3T_i}{GL_i c_i^3} \quad \Rightarrow \quad T_i = \frac{\theta_1 GL_i c_i^3}{3}$$

$$T = T_1 + T_2 + T_3 = \frac{\theta_1 G}{3} \sum_{i=1}^3 L_i c_i^3 \quad \text{Ans.}$$

From Eq. (3-47),  $\tau = G\theta_1 c$

$G$  and  $\theta_1$  are constant, therefore the largest shear stress occurs when  $c$  is a maximum.

$$\tau_{\max} = G\theta_1 c_{\max} \quad \text{Ans.}$$

### 3-53

(b) Solve part (b) first since the twist is needed for part (a).

$$\tau_{\max} = \tau_{\text{allow}} = 12(6.89) = 82.7 \text{ MPa}$$

$$\theta_1 = \frac{\tau_{\max}}{Gc_{\max}} = \frac{82.7(10^6)}{79.3(10^9)(0.003)} = 0.348 \text{ rad/m} \quad \text{Ans.}$$

(a)

$$T_1 = \frac{\theta_1 GL_1 c_1^3}{3} = \frac{0.348(79.3)(10^9)(0.020)(0.002^3)}{3} = 1.47 \text{ N} \cdot \text{m} \quad \text{Ans.}$$

$$T_2 = \frac{\theta_2 GL_2 c_2^3}{3} = \frac{0.348(79.3)(10^9)(0.030)(0.003^3)}{3} = 7.45 \text{ N} \cdot \text{m} \quad \text{Ans.}$$

$$T_3 = \frac{\theta_3 GL_3 c_3^3}{3} = \frac{0.348(79.3)(10^9)(0)(0^3)}{3} = 0 \quad \text{Ans.}$$

$$T = T_1 + T_2 + T_3 = 1.47 + 7.45 + 0 = 8.92 \text{ N} \cdot \text{m} \quad \text{Ans.}$$

**3-54**

(b) Solve part (b) first since the twist is needed for part (a).

$$\theta_1 = \frac{\tau_{\max}}{Gc_{\max}} = \frac{12000}{11.5(10^6)(0.125)} = 8.35(10^{-3}) \text{ rad/in} \quad \text{Ans.}$$

(a)

$$T_1 = \frac{\theta_1 GL_1 c_1^3}{3} = \frac{(8.35)(10^{-3})(11.5)(10^6)(0.75)(0.0625^3)}{3} = 5.86 \text{ lbf} \cdot \text{in} \quad \text{Ans.}$$

$$T_2 = \frac{\theta_2 GL_2 c_2^3}{3} = \frac{(8.35)(10^{-3})(11.5)(10^6)(1)(0.125^3)}{3} = 62.52 \text{ lbf} \cdot \text{in} \quad \text{Ans.}$$

$$T_3 = \frac{\theta_3 GL_3 c_3^3}{3} = \frac{(8.35)(10^{-3})(11.5)(10^6)(0.625)(0.0625^3)}{3} = 4.88 \text{ lbf} \cdot \text{in} \quad \text{Ans.}$$

$$T = T_1 + T_2 + T_3 = 5.86 + 62.52 + 4.88 = 73.3 \text{ lbf} \cdot \text{in} \quad \text{Ans.}$$

---

**3-55**

(b) Solve part (b) first since the twist is needed for part (a).

$$\tau_{\max} = \tau_{\text{allow}} = 12(6.89) = 82.7 \text{ MPa}$$

$$\theta_1 = \frac{\tau_{\max}}{Gc_{\max}} = \frac{82.7(10^6)}{79.3(10^9)(0.003)} = 0.348 \text{ rad/m} \quad \text{Ans.}$$

(a)

$$T_1 = \frac{\theta_1 GL_1 c_1^3}{3} = \frac{0.348(79.3)(10^9)(0.020)(0.002^3)}{3} = 1.47 \text{ N} \cdot \text{m} \quad \text{Ans.}$$

$$T_2 = \frac{\theta_2 GL_2 c_2^3}{3} = \frac{0.348(79.3)(10^9)(0.030)(0.003^3)}{3} = 7.45 \text{ N} \cdot \text{m} \quad \text{Ans.}$$

$$T_3 = \frac{\theta_3 GL_3 c_3^3}{3} = \frac{0.348(79.3)(10^9)(0.025)(0.002^3)}{3} = 1.84 \text{ N} \cdot \text{m} \quad \text{Ans.}$$

$$T = T_1 + T_2 + T_3 = 1.47 + 7.45 + 1.84 = 10.8 \text{ N} \cdot \text{m} \quad \text{Ans.}$$

---

**3-56**

(a) From Eq. (3-40), with two 2-mm strips,

$$T = \frac{\tau_{\max} bc^2}{3 + 1.8/(b/c)} = \frac{(80)(10^6)(0.030)(0.002^2)}{3 + 1.8/(0.030/0.002)} = 3.08 \text{ N} \cdot \text{m}$$

$$T_{\max} = 2(3.08) = 6.16 \text{ N} \cdot \text{m} \quad \text{Ans.}$$

From the table on p. 102, with  $b/c = 30/2 = 15$ ,  $\alpha = \beta$  and has a value between 0.313 and 0.333.

From Eq. (3-40),

$$\alpha \doteq \frac{1}{3 + 1.8/(30/2)} = 0.321$$

From Eq. (3-41),

$$\theta = \frac{Tl}{\beta bc^3 G} = \frac{3.08(0.3)}{0.321(0.030)(0.002^3)(79.3)(10^9)} = 0.151 \text{ rad} \quad \text{Ans.}$$

$$k_t = \frac{T}{\theta} = \frac{6.16}{0.151} = 40.8 \text{ N} \cdot \text{m} \quad \text{Ans.}$$

From Eq. (3-40), with a single 4-mm strip,

$$T_{\max} = \frac{\tau_{\max} bc^2}{3 + 1.8/(b/c)} = \frac{(80)(10^6)(0.030)(0.004^2)}{3 + 1.8/(0.030/0.004)} = 11.9 \text{ N} \cdot \text{m} \quad \text{Ans.}$$

Interpolating from the table on p. 102, with  $b/c = 30/4 = 7.5$ ,

$$\beta = \frac{7.5 - 6}{8 - 6} (0.307 - 0.299) + 0.299 = 0.305$$

From Eq. (3-41)

$$\theta = \frac{Tl}{\beta bc^3 G} = \frac{11.9(0.3)}{0.305(0.030)(0.004^3)(79.3)(10^9)} = 0.0769 \text{ rad} \quad \text{Ans.}$$

$$k_t = \frac{T}{\theta} = \frac{11.9}{0.0769} = 155 \text{ N} \cdot \text{m} \quad \text{Ans.}$$

**(b)** From Eq. (3-47), with two 2-mm strips,

$$T = \frac{Lc^2 \tau}{3} = \frac{(0.030)(0.002^2)(80)(10^6)}{3} = 3.20 \text{ N} \cdot \text{m}$$

$$T_{\max} = 2(3.20) = 6.40 \text{ N} \cdot \text{m} \quad \text{Ans.}$$

$$\theta = \frac{3Tl}{Lc^3 G} = \frac{3(3.20)(0.3)}{(0.030)(0.002^3)(79.3)(10^9)} = 0.151 \text{ rad} \quad \text{Ans.}$$

$$k_t = T/\theta = 6.40/0.151 = 42.4 \text{ N} \cdot \text{m} \quad \text{Ans.}$$

From Eq. (3-47), with a single 4-mm strip,

$$T_{\max} = \frac{Lc^2 \tau}{3} = \frac{(0.030)(0.004^2)(80)(10^6)}{3} = 12.8 \text{ N} \cdot \text{m} \quad \text{Ans.}$$

$$\theta = \frac{3Tl}{Lc^3G} = \frac{3(12.8)(0.3)}{(0.030)(0.004^3)(79.3)(10^9)} = 0.0757 \text{ rad} \quad \text{Ans.}$$

$$k_t = T/\theta = 12.8/0.0757 = 169 \text{ N} \cdot \text{m} \quad \text{Ans.}$$

The results for the spring constants when using Eq. (3-47) are slightly larger than when using Eq. (3-40) and Eq. (3-41) because the strips are not infinitesimally thin (i.e.  $b/c$  does not equal infinity). The spring constants when considering one solid strip are significantly larger (almost four times larger) than when considering two thin strips because two thin strips would be able to slip along the center plane.

### 3-57

(a) Obtain the torque from the given power and speed using Eq. (3-44).

$$T = 9.55 \frac{H}{n} = 9.55 \frac{(40000)}{2500} = 152.8 \text{ N} \cdot \text{m}$$

$$\tau_{\max} = \frac{Tr}{J} = \frac{16T}{\pi d^3}$$

$$d = \left( \frac{16T}{\pi \tau_{\max}} \right)^{1/3} = \left[ \frac{16(152.8)}{\pi(70)(10^6)} \right]^{1/3} = 0.0223 \text{ m} = 22.3 \text{ mm} \quad \text{Ans.}$$

(b)  $T = 9.55 \frac{H}{n} = 9.55 \frac{(40000)}{250} = 1528 \text{ N} \cdot \text{m}$

$$d = \left[ \frac{16(1528)}{\pi(70)(10^6)} \right]^{1/3} = 0.0481 \text{ m} = 48.1 \text{ mm} \quad \text{Ans.}$$

### 3-58

(a) Obtain the torque from the given power and speed using Eq. (3-42).

$$T = \frac{63025H}{n} = \frac{63025(50)}{2500} = 1261 \text{ lbf} \cdot \text{in}$$

$$\tau_{\max} = \frac{Tr}{J} = \frac{16T}{\pi d^3}$$

$$d = \left( \frac{16T}{\pi \tau_{\max}} \right)^{1/3} = \left[ \frac{16(1261)}{\pi(20000)} \right]^{1/3} = 0.685 \text{ in} \quad \text{Ans.}$$

(b)  $T = \frac{63025H}{n} = \frac{63025(50)}{250} = 12610 \text{ lbf} \cdot \text{in}$

$$d = \left[ \frac{16(12610)}{\pi(20000)} \right]^{1/3} = 1.48 \text{ in} \quad \text{Ans.}$$

**3-59**

$$\tau_{\max} = \frac{16T}{\pi d^3} \Rightarrow T = \frac{\tau_{\max} \pi d^3}{16} = \frac{(50)(10^6) \pi (0.03^3)}{16} = 265 \text{ N} \cdot \text{m}$$

$$\text{Eq. (3-44), } H = \frac{Tn}{9.55} = \frac{265(2000)}{9.55} = 55.5(10^3) \text{ W} = 55.5 \text{ kW} \quad \text{Ans.}$$

---

**3-60**

$$\tau = \frac{16T}{\pi d^3} \Rightarrow T = \frac{\pi}{16} \tau d^3 = \frac{\pi}{16} (110)(10^6)(0.020^3) = 173 \text{ N} \cdot \text{m}$$

$$\theta = \frac{Tl}{JG} \Rightarrow l = \frac{\pi d^4 G \theta}{32T} = \frac{\pi (0.020^4)(79.3)(10^9) \left(15 \frac{\pi}{180}\right)}{32(173)}$$

$$l = 1.89 \text{ m} \quad \text{Ans.}$$

---

**3-61**

$$\tau = \frac{16T}{\pi d^3} \Rightarrow T = \frac{\pi}{16} \tau d^3 = \frac{\pi}{16} (30\,000)(0.75^3) = 2485 \text{ lbf} \cdot \text{in}$$

$$\theta = \frac{Tl}{JG} = \frac{32Tl}{\pi d^4 G} = \frac{32(2485)(24)}{\pi (0.75^4)(11.5)(10^6)} = 0.167 \text{ rad} = 9.57^\circ \quad \text{Ans.}$$

---

**3-62**

$$\text{(a) } T_{\text{solid}} = \frac{J\tau_{\max}}{r} = \frac{\pi d_o^4 \tau_{\max}}{16d_o} \quad T_{\text{hollow}} = \frac{J\tau_{\max}}{r} = \frac{\pi(d_o^4 - d_i^4)\tau_{\max}}{16d_o}$$

$$\% \Delta T = \frac{T_{\text{solid}} - T_{\text{hollow}}}{T_{\text{solid}}} (100\%) = \frac{d_i^4}{d_o^4} (100\%) = \frac{(36^4)}{(40^4)} (100\%) = 65.6\% \quad \text{Ans.}$$

$$\text{(b) } W_{\text{solid}} = kd_o^2, \quad W_{\text{hollow}} = k(d_o^2 - d_i^2)$$

$$\% \Delta W = \frac{W_{\text{solid}} - W_{\text{hollow}}}{W_{\text{solid}}} (100\%) = \frac{d_i^2}{d_o^2} (100\%) = \frac{(36^2)}{(40^2)} (100\%) = 81.0\% \quad \text{Ans.}$$

---

**3-63**

$$\text{(a) } T_{\text{solid}} = \frac{J\tau_{\max}}{r} = \frac{\pi d^4 \tau_{\max}}{16d} \quad T_{\text{hollow}} = \frac{J\tau_{\max}}{r} = \frac{\pi [d^4 - (xd)^4] \tau_{\max}}{16d}$$

$$\% \Delta T = \frac{T_{\text{solid}} - T_{\text{hollow}}}{T_{\text{solid}}} (100\%) = \frac{(xd)^4}{d^4} (100\%) = x^4 (100\%) \quad \text{Ans.}$$

$$(b) W_{\text{solid}} = kd^2 \quad W_{\text{hollow}} = k(d^2 - (xd)^2)$$

$$\% \Delta W = \frac{W_{\text{solid}} - W_{\text{hollow}}}{W_{\text{solid}}} (100\%) = \frac{(xd)^2}{d^2} (100\%) = x^2 (100\%) \quad \text{Ans.}$$

Plot  $\% \Delta T$  and  $\% \Delta W$  versus  $x$ .

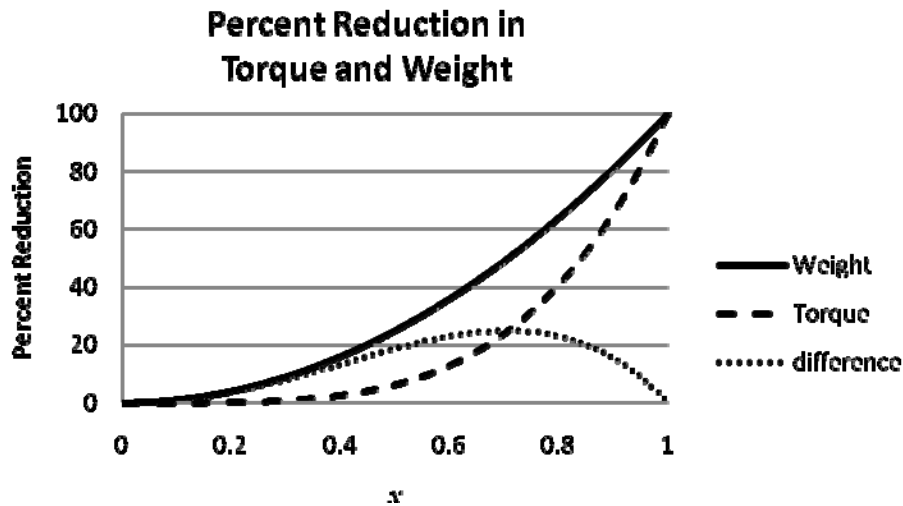

The value of greatest difference in percent reduction of weight and torque is 25% and occurs at  $x = \sqrt{2}/2$ .

### 3-64

$$(a) \tau = \frac{Tc}{J} \Rightarrow 120(10^6) = \frac{4200(d/2)}{(\pi/32)[d^4 - (0.70d)^4]} = \frac{2.8149(10^4)}{d^3}$$

$$d = \left( \frac{2.8149(10^4)}{120(10^6)} \right)^{1/3} = 6.17(10^{-2}) \text{ m} = 61.7 \text{ mm}$$

From Table A-17, the next preferred size is  $d = 80 \text{ mm}$ . *Ans.*

$d_i = 0.7d = 56 \text{ mm}$ . The next preferred size smaller is  $d_i = 50 \text{ mm}$  *Ans.*

(b)

$$\tau = \frac{Tc}{J} = \frac{4200(d_i/2)}{(\pi/32)[d^4 - (d_i)^4]} = \frac{4200(0.050/2)}{(\pi/32)[(0.080)^4 - (0.050)^4]} = 30.8 \text{ MPa} \quad \text{Ans.}$$

**3-65**

$$T = 9.55 \frac{H}{n} = 9.55 \frac{(1500)}{10} = 1433 \text{ N} \cdot \text{m}$$

$$\tau = \frac{16T}{\pi d_C^3} \Rightarrow d_C = \left( \frac{16T}{\pi \tau} \right)^{1/3} = \left[ \frac{16(1433)}{\pi(80)(10^6)} \right]^{1/3} = 0.045 \text{ m} = 45 \text{ mm}$$

From Table A-17, select 50 mm. *Ans.*

$$(a) \tau_{\text{start}} = \frac{16(2)(1433)}{\pi(0.050^3)} = 117(10^6) \text{ Pa} = 117 \text{ MPa} \quad \textit{Ans.}$$

(b) Design activity

**3-66**

$$T = \frac{63\,025H}{n} = \frac{63\,025(1)}{8} = 7880 \text{ lbf} \cdot \text{in}$$

$$\tau = \frac{16T}{\pi d_C^3} \Rightarrow d_C = \left( \frac{16T}{\pi \tau} \right)^{1/3} = \left[ \frac{16(7880)}{\pi(15\,000)} \right]^{1/3} = 1.39 \text{ in}$$

From Table A-17, select 1.40 in. *Ans.*

**3-67** For a square cross section with side length  $b$ , and a circular section with diameter  $d$ ,

$$A_{\text{square}} = A_{\text{circular}} \Rightarrow b^2 = \frac{\pi}{4} d^2 \Rightarrow b = \frac{\sqrt{\pi}}{2} d$$

From Eq. (3-40) with  $b = c$ ,

$$(\tau_{\text{max}})_{\text{square}} = \frac{T}{bc^2} \left( 3 + \frac{1.8}{b/c} \right) = \frac{T}{b^3} \left( 3 + \frac{1.8}{1} \right) = \frac{T}{d^3} \left( \frac{2}{\sqrt{\pi}} \right)^3 (4.8) = 6.896 \frac{T}{d^3}$$

For the circular cross section,

$$(\tau_{\text{max}})_{\text{circular}} = \frac{16T}{\pi d^3} = 5.093 \frac{T}{d^3}$$

$$\frac{(\tau_{\text{max}})_{\text{square}}}{(\tau_{\text{max}})_{\text{circular}}} = \frac{6.896 \frac{T}{d^3}}{5.093 \frac{T}{d^3}} = 1.354$$

The shear stress in the square cross section is 35.4% greater. *Ans.*

(b) For the square cross section, from the table on p. 102,  $\beta = 0.141$ . From Eq. (3-41),

$$\theta_{\text{square}} = \frac{Tl}{\beta bc^3 G} = \frac{Tl}{\beta b^4 G} = \frac{Tl}{0.141 \left( \frac{\sqrt{\pi}}{2} d \right)^4 G} = 11.50 \frac{Tl}{d^4 G}$$

For the circular cross section,

$$\theta_{rd} = \frac{Tl}{GJ} = \frac{Tl}{G(\pi d^4/32)} = 10.19 \frac{Tl}{d^4 G}$$

$$\frac{\theta_{sq}}{\theta_{rd}} = \frac{11.50 \frac{Tl}{d^4 G}}{10.19 \frac{Tl}{d^4 G}} = 1.129$$

The angle of twist in the square cross section is 12.9% greater. *Ans.*

**3-68 (a)**

$$T_1 = 0.15T_2$$

$$\sum T = 0 = (500 - 75)(4) - (T_2 - T_1)(5) = 1700 - (T_2 - 0.15T_2)(5)$$

$$1700 - 4.25T_2 = 0 \quad \Rightarrow \quad T_2 = 400 \text{ lbf} \quad \textit{Ans.}$$

$$T_1 = 0.15(400) = 60 \text{ lbf} \quad \textit{Ans.}$$

**(b)**

$$\sum M_O = 0 = -575(10) + 460(28) - R_C(40)$$

$$R_C = 178.25 \doteq 178 \text{ lbf} \quad \textit{Ans.}$$

$$\sum F = 0 = R_O + 575 - 460 + 178.25$$

$$R_O = -293.25 \text{ lbf} \quad \textit{Ans.}$$

**(c)**

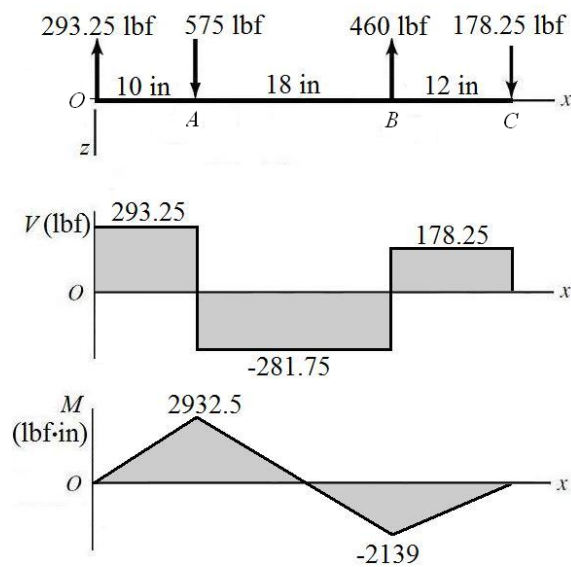



(d) The maximum bending moment is at  $x = 10$  in, and is  $M = 2932.5$  lbf-in. Since the shaft rotates, each stress element will experience both positive and negative bending stress as it moves from tension to compression. The torque transmitted through the shaft from  $A$  to  $B$  is  $T = (500 - 75)(4) = 1700$  lbf-in. For a stress element on the outer surface where the bending stress and the torsional stress are both maximum,

$$\sigma = \frac{Mc}{I} = \frac{32M}{\pi d^3} = \frac{32(2932.5)}{\pi(1.25)^3} = 15\,294 \text{ psi} = 15.3 \text{ kpsi} \quad \text{Ans.}$$

$$\tau = \frac{Tr}{J} = \frac{16T}{\pi d^3} = \frac{16(1700)}{\pi(1.25)^3} = 4433 \text{ psi} = 4.43 \text{ kpsi} \quad \text{Ans.}$$

(e)

$$\sigma_1, \sigma_2 = \frac{\sigma_x}{2} \pm \sqrt{\left(\frac{\sigma_x}{2}\right)^2 + (\tau_{xy})^2} = \frac{15.3}{2} \pm \sqrt{\left(\frac{15.3}{2}\right)^2 + (4.43)^2}$$

$$\sigma_1 = 16.5 \text{ kpsi} \quad \text{Ans.}$$

$$\sigma_2 = -1.19 \text{ kpsi} \quad \text{Ans.}$$

$$\tau_{\max} = \sqrt{\left(\frac{\sigma_x}{2}\right)^2 + (\tau_{xy})^2} = \sqrt{\left(\frac{15.3}{2}\right)^2 + (4.43)^2} = 8.84 \text{ kpsi} \quad \text{Ans.}$$

**3-69 (a)**

$$T_2 = 0.15T_1$$

$$\sum T = 0 = (1800 - 270)(200) + (T_2 - T_1)(125) = 306(10^3) + 125(0.15T_1 - T_1)$$

$$306(10^3) - 106.25T_1 = 0 \quad \Rightarrow \quad T_1 = 2880 \text{ N} \quad \text{Ans.}$$

$$T_2 = 0.15(2880) = 432 \text{ N} \quad \text{Ans.}$$

(b)

$$\sum M_O = 0 = 3312(230) + R_C(510) - 2070(810)$$

$$R_C = 1794 \text{ N} \quad \text{Ans.}$$

$$\sum F_y = 0 = R_O + 3312 + 1794 - 2070$$

$$R_O = -3036 \text{ N} \quad \text{Ans.}$$

(c)

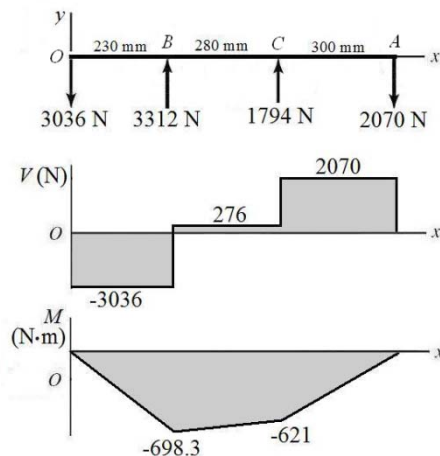

(d) The maximum bending moment is at  $x = 230$  mm, and is  $M = -698.3$  N·m. Since the shaft rotates, each stress element will experience both positive and negative bending stress as it moves from tension to compression. The torque transmitted through the shaft from  $A$  to  $B$  is  $T = (1800 - 270)(0.200) = 306$  N·m. For a stress element on the outer surface where the bending stress and the torsional stress are both maximum,

$$\sigma = \frac{Mc}{I} = \frac{32M}{\pi d^3} = \frac{32(698.3)}{\pi(0.030)^3} = 263(10^3) \text{ Pa} = 263 \text{ MPa} \quad \text{Ans.}$$

$$\tau = \frac{Tr}{J} = \frac{16T}{\pi d^3} = \frac{16(306)}{\pi(0.030)^3} = 57.7(10^6) \text{ Pa} = 57.7 \text{ MPa} \quad \text{Ans.}$$

(e)

$$\sigma_1, \sigma_2 = \frac{\sigma_x}{2} \pm \sqrt{\left(\frac{\sigma_x}{2}\right)^2 + (\tau_{xy})^2} = \frac{263}{2} \pm \sqrt{\left(\frac{263}{2}\right)^2 + (57.7)^2}$$

$$\sigma_1 = 275 \text{ MPa} \quad \text{Ans.}$$

$$\sigma_2 = -12.1 \text{ MPa} \quad \text{Ans.}$$

$$\tau_{\max} = \sqrt{\left(\frac{\sigma_x}{2}\right)^2 + (\tau_{xy})^2} = \sqrt{\left(\frac{263}{2}\right)^2 + (57.7)^2} = 144 \text{ MPa} \quad \text{Ans.}$$

### 3-70

(a)

$$T_2 = 0.15T_1$$

$$\sum T = 0 = (300 - 50)(4) + (T_2 - T_1)(3) = 1000 + (0.15T_1 - T_1)(3)$$

$$1000 - 2.55T_1 = 0 \quad \Rightarrow \quad T_1 = 392.16 \text{ lbf} \quad \text{Ans.}$$

$$T_2 = 0.15(392.16) = 58.82 \text{ lbf} \quad \text{Ans.}$$

(b)

$$\sum M_{O_y} = 0 = -450.98(16) - R_{C_z}(22)$$

$$R_{C_z} = -327.99 \text{ lbf } \textit{Ans.}$$

$$\sum F_z = 0 = R_{O_z} + 450.98 - 327.99$$

$$R_{O_z} = -122.99 \text{ lbf } \textit{Ans.}$$

$$\sum M_{O_z} = 0 = 350(8) + R_{C_y}(22)$$

$$R_{C_y} = -127.27 \text{ lbf } \textit{Ans.}$$

$$\sum F_y = 0 = R_{O_y} + 350 - 127.27$$

$$R_{O_y} = -222.73 \text{ lbf } \textit{Ans.}$$

(c)

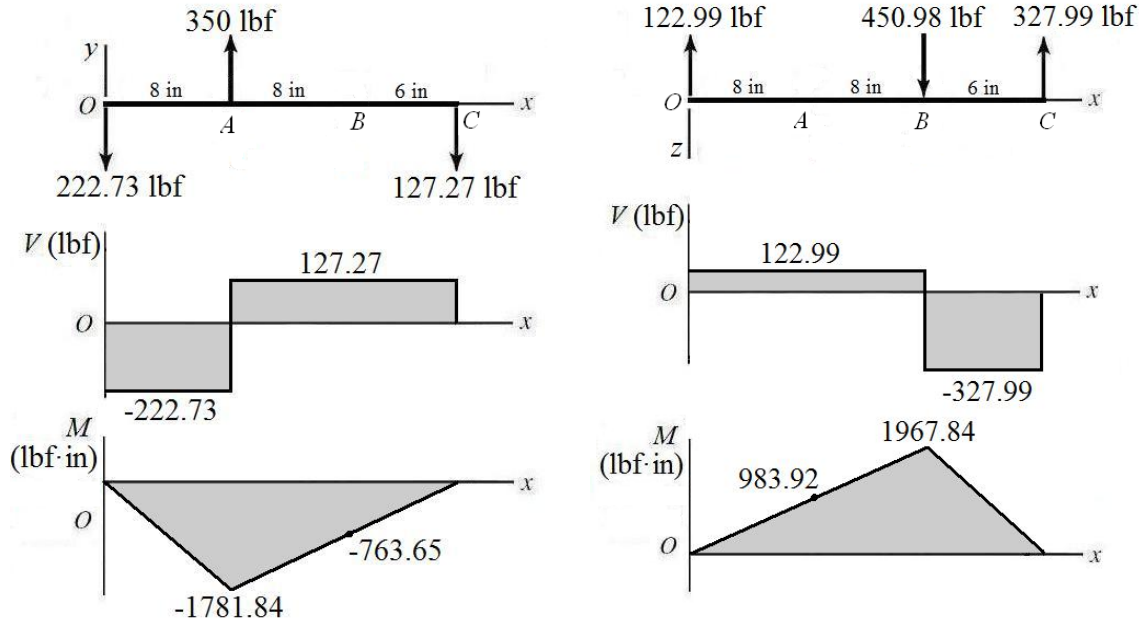

(d) Combine the bending moments from both planes at A and B to find the critical location.

$$M_A = \sqrt{(983.92)^2 + (-1781.84)^2} = 2035 \text{ lbf} \cdot \text{in}$$

$$M_B = \sqrt{(1967.84)^2 + (-763.65)^2} = 2111 \text{ lbf} \cdot \text{in}$$

The critical location is at B. The torque transmitted through the shaft from A to B is  $T = (300 - 50)(4) = 1000 \text{ lbf} \cdot \text{in}$ . For a stress element on the outer surface where the bending stress and the torsional stress are both maximum,

$$\sigma = \frac{Mc}{I} = \frac{32M}{\pi d^3} = \frac{32(2111)}{\pi(1)^3} = 21502 \text{ psi} = 21.5 \text{ kpsi} \quad \text{Ans.}$$

$$\tau = \frac{Tr}{J} = \frac{16T}{\pi d^3} = \frac{16(1000)}{\pi(1)^3} = 5093 \text{ psi} = 5.09 \text{ kpsi} \quad \text{Ans.}$$

(e)

$$\sigma_1, \sigma_2 = \frac{\sigma_x}{2} \pm \sqrt{\left(\frac{\sigma_x}{2}\right)^2 + (\tau_{xy})^2} = \frac{21.5}{2} \pm \sqrt{\left(\frac{21.5}{2}\right)^2 + (5.09)^2}$$

$$\sigma_1 = 22.6 \text{ kpsi} \quad \text{Ans.}$$

$$\sigma_2 = -1.14 \text{ kpsi} \quad \text{Ans.}$$

$$\tau_{\max} = \sqrt{\left(\frac{\sigma_x}{2}\right)^2 + (\tau_{xy})^2} = \sqrt{\left(\frac{21.5}{2}\right)^2 + (5.09)^2} = 11.9 \text{ kpsi} \quad \text{Ans.}$$

**3-71 (a)**

$$T_2 = 0.15T_1$$

$$\sum T = 0 = (300 - 45)(125) + (T_2 - T_1)(150) = 31\,875 + (0.15T_1 - T_1)(150)$$

$$31\,875 - 127.5T_1 = 0 \Rightarrow T_1 = 250 \text{ N}\cdot\text{mm} \text{ Ans.}$$

$$T_2 = 0.15(250) = 37.5 \text{ N}\cdot\text{mm} \text{ Ans.}$$

**(b)**

$$\sum M_{O_y} = 0 = 345 \sin 45^\circ (300) - 287.5(700) - R_{C_z}(850)$$

$$R_{C_z} = -150.7 \text{ N} \text{ Ans.}$$

$$\sum F_z = 0 = R_{O_z} - 345 \cos 45^\circ + 287.5 - 150.7$$

$$R_{O_z} = 107.2 \text{ N} \text{ Ans.}$$

$$\sum M_{O_z} = 0 = 345 \sin 45^\circ (300) + R_{C_y}(850)$$

$$R_{C_y} = -86.10 \text{ N} \text{ Ans.}$$

$$\sum F_y = 0 = R_{O_y} + 345 \cos 45^\circ - 86.10$$

$$R_{O_y} = -157.9 \text{ N} \text{ Ans.}$$

**(c)**

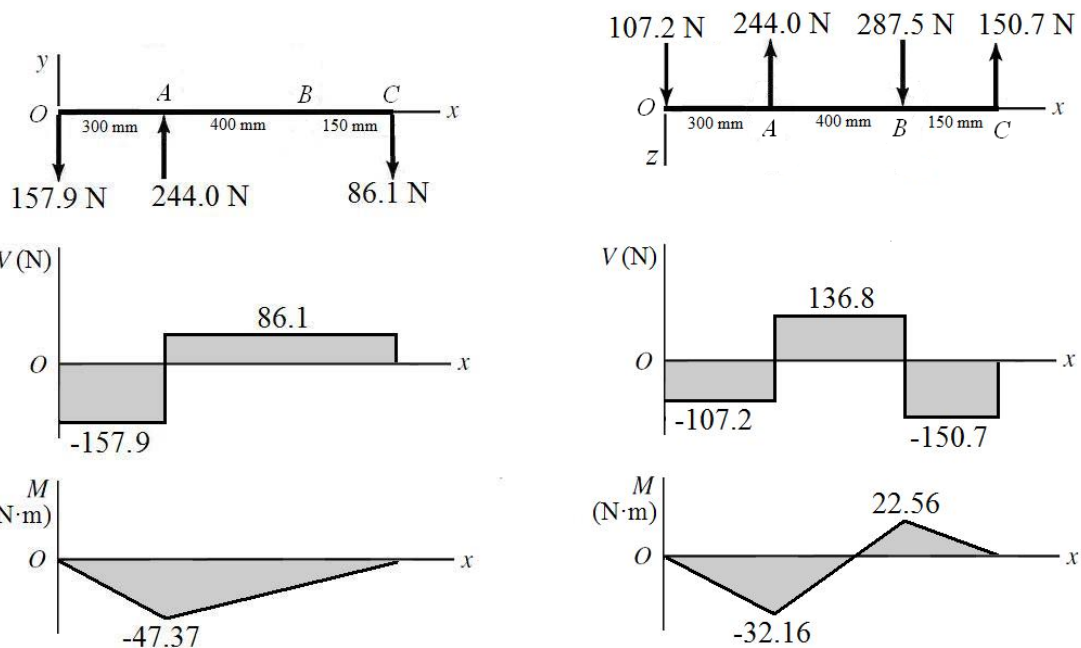

n

ding moment diagrams, it is clear that the critical location is at A where both planes have the maximum bending moment. Combining the bending moments from the two planes,

$$M = \sqrt{(-47.37)^2 + (-32.16)^2} = 57.26 \text{ N}\cdot\text{m}$$

The torque transmitted through the shaft from  $A$  to  $B$  is  $T = (300 - 45)(0.125) = 31.88$  N·m. For a stress element on the outer surface where the bending stress and the torsional stress are both maximum,

$$\sigma = \frac{Mc}{I} = \frac{32M}{\pi d^3} = \frac{32(57.26)}{\pi(0.020)^3} = 72.9(10^6) \text{ Pa} = 72.9 \text{ MPa} \quad \text{Ans.}$$

$$\tau = \frac{Tr}{J} = \frac{16T}{\pi d^3} = \frac{16(31.88)}{\pi(0.020)^3} = 20.3(10^6) \text{ Pa} = 20.3 \text{ MPa} \quad \text{Ans.}$$

(e)

$$\sigma_1, \sigma_2 = \frac{\sigma_x}{2} \pm \sqrt{\left(\frac{\sigma_x}{2}\right)^2 + (\tau_{xy})^2} = \frac{72.9}{2} \pm \sqrt{\left(\frac{72.9}{2}\right)^2 + (20.3)^2}$$

$$\sigma_1 = 78.2 \text{ MPa} \quad \text{Ans.}$$

$$\sigma_2 = -5.27 \text{ MPa} \quad \text{Ans.}$$

$$\tau_{\max} = \sqrt{\left(\frac{\sigma_x}{2}\right)^2 + (\tau_{xy})^2} = \sqrt{\left(\frac{72.9}{2}\right)^2 + (20.3)^2} = 41.7 \text{ MPa} \quad \text{Ans.}$$

### 3-72

(a)

$$\sum T = 0 = -300(\cos 20^\circ)(10) + F_B(\cos 20^\circ)(4)$$

$$F_B = 750 \text{ lbf} \quad \text{Ans.}$$

(b)

$$\sum M_{O_z} = 0 = 300(\cos 20^\circ)(16) - 750(\sin 20^\circ)(39) + R_{C_y}(30)$$

$$R_{C_y} = 183.1 \text{ lbf} \quad \text{Ans.}$$

$$\sum F_y = 0 = R_{O_y} + 300(\cos 20^\circ) + 183.1 - 750(\sin 20^\circ)$$

$$R_{O_y} = -208.5 \text{ lbf} \quad \text{Ans.}$$

$$\sum M_{O_y} = 0 = 300(\sin 20^\circ)(16) - R_{C_z}(30) - 750(\cos 20^\circ)(39)$$

$$R_{C_z} = -861.5 \text{ lbf} \quad \text{Ans.}$$

$$\sum F_z = 0 = R_{O_z} - 300(\sin 20^\circ) - 861.5 + 750(\cos 20^\circ)$$

$$R_{O_z} = 259.3 \text{ lbf} \quad \text{Ans.}$$

(c)

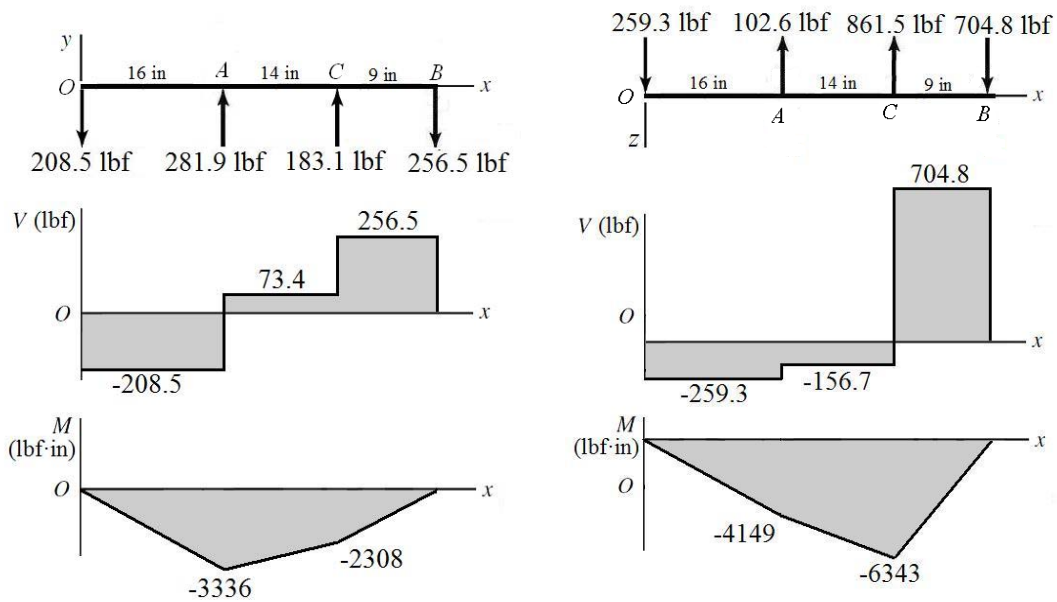

(d) Combine the bending moments from both planes at A and C to find the critical location.

$$M_A = \sqrt{(-3336)^2 + (-4149)^2} = 5324 \text{ lbf} \cdot \text{in}$$

$$M_C = \sqrt{(-2308)^2 + (-6343)^2} = 6750 \text{ lbf} \cdot \text{in}$$

The critical location is at C. The torque transmitted through the shaft from A to B is  $T = 300 \cos(20^\circ)(10) = 2819 \text{ lbf} \cdot \text{in}$ . For a stress element on the outer surface where the bending stress and the torsional stress are both maximum,

$$\sigma = \frac{Mc}{I} = \frac{32M}{\pi d^3} = \frac{32(6750)}{\pi(1.25)^3} = 35\,203 \text{ psi} = 35.2 \text{ kpsi} \quad \text{Ans.}$$

$$\tau = \frac{Tr}{J} = \frac{16T}{\pi d^3} = \frac{16(2819)}{\pi(1.25)^3} = 7351 \text{ psi} = 7.35 \text{ kpsi} \quad \text{Ans.}$$

(e)

$$\sigma_1, \sigma_2 = \frac{\sigma_x}{2} \pm \sqrt{\left(\frac{\sigma_x}{2}\right)^2 + (\tau_{xy})^2} = \frac{35.2}{2} \pm \sqrt{\left(\frac{35.2}{2}\right)^2 + (7.35)^2}$$

$$\sigma_1 = 36.7 \text{ kpsi} \quad \text{Ans.}$$

$$\sigma_2 = -1.47 \text{ kpsi} \quad \text{Ans.}$$

$$\tau_{\max} = \sqrt{\left(\frac{\sigma_x}{2}\right)^2 + (\tau_{xy})^2} = \sqrt{\left(\frac{35.2}{2}\right)^2 + (7.35)^2} = 19.1 \text{ kpsi} \quad \text{Ans.}$$

3-73

(a)

$$\sum T = 0 = -11\,000(\cos 20^\circ)(300) + F_B(\cos 25^\circ)(150)$$

$$F_B = 22\,810 \text{ N} \quad \text{Ans.}$$

(b)

$$\sum M_{O_z} = 0 = -11\,000(\sin 20^\circ)(400) - 22\,810(\sin 25^\circ)(750) + R_{C_y}(1050)$$

$$R_{C_y} = 8319 \text{ N} \quad \text{Ans.}$$

$$\sum F_y = 0 = R_{O_y} - 11\,000(\sin 20^\circ) - 22\,810 \sin(25^\circ) + 8319$$

$$R_{O_y} = 5083 \text{ N} \quad \text{Ans.}$$

$$\sum M_{O_y} = 0 = 11\,000(\cos 20^\circ)(400) - 22\,810(\cos 25^\circ)(750) - R_{C_z}(1050)$$

$$R_{C_z} = -10\,830 \text{ N} \quad \text{Ans.}$$

$$\sum F_z = 0 = R_{O_z} - 11\,000(\cos 20^\circ) + 22\,810(\cos 25^\circ) - 10\,830$$

$$R_{O_z} = 494 \text{ N} \quad \text{Ans.}$$

(c)

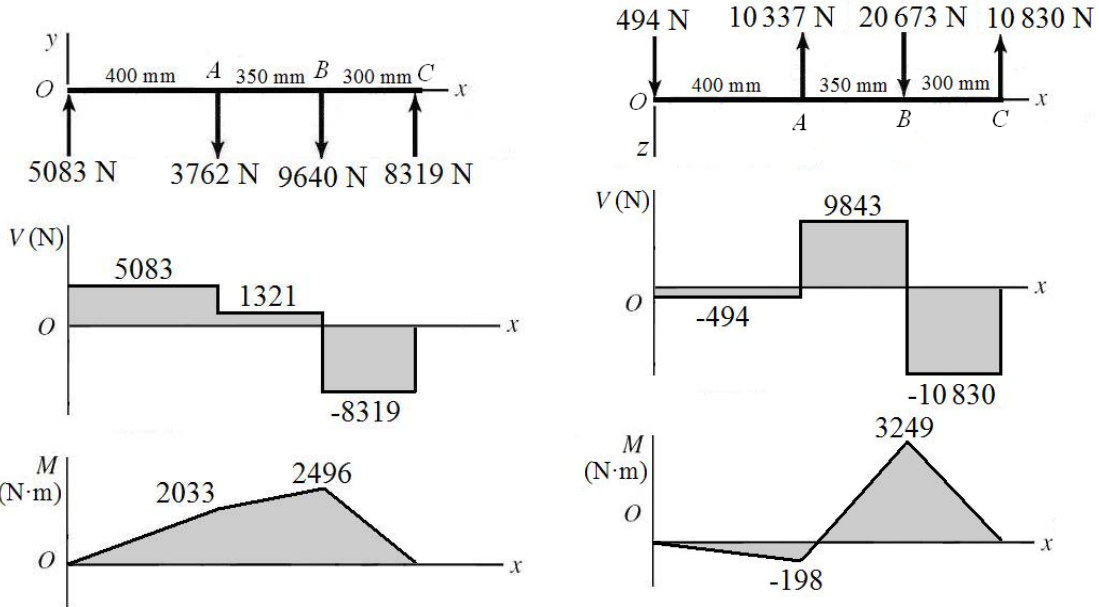

(d) From the bending moment diagrams, it is clear that the critical location is at B where both planes have the maximum bending moment. Combining the bending moments from the two planes,

$$M = \sqrt{(2496)^2 + (3249)^2} = 4097 \text{ N} \cdot \text{m}$$

The torque transmitted through the shaft from A to B is

$$T = 11\,000 \cos(20^\circ)(0.3) = 3101 \text{ N} \cdot \text{m}.$$

For a stress element on the outer surface where the bending stress and the torsional stress are both maximum,



$$\sigma = \frac{Mc}{I} = \frac{32M}{\pi d^3} = \frac{32(4097)}{\pi(0.050)^3} = 333.9(10^6) \text{ Pa} = 333.9 \text{ MPa} \quad \text{Ans.}$$

$$\tau = \frac{Tr}{J} = \frac{16T}{\pi d^3} = \frac{16(3101)}{\pi(0.050)^3} = 126.3(10^6) \text{ Pa} = 126.3 \text{ MPa} \quad \text{Ans.}$$

(e)

$$\sigma_1, \sigma_2 = \frac{\sigma_x}{2} \pm \sqrt{\left(\frac{\sigma_x}{2}\right)^2 + (\tau_{xy})^2} = \frac{333.9}{2} \pm \sqrt{\left(\frac{333.9}{2}\right)^2 + (126.3)^2}$$

$$\sigma_1 = 376 \text{ MPa} \quad \text{Ans.}$$

$$\sigma_2 = -42.4 \text{ MPa} \quad \text{Ans.}$$

$$\tau_{\max} = \sqrt{\left(\frac{\sigma_x}{2}\right)^2 + (\tau_{xy})^2} = \sqrt{\left(\frac{333.9}{2}\right)^2 + (126.3)^2} = 209 \text{ MPa} \quad \text{Ans.}$$

### 3-74

(a)

$$(\Sigma M_D)_z = 6.13C_x - 3.8(92.8) - 3.88(362.8) = 0$$

$$C_x = 287.2 \text{ lbf} \quad \text{Ans.}$$

$$(\Sigma M_C)_z = 6.13D_x + 2.33(92.8) - 3.88(362.8) = 0$$

$$D_x = 194.4 \text{ lbf} \quad \text{Ans.}$$

$$(\Sigma M_D)_x = 0 \Rightarrow C_z = \frac{3.8}{6.13}(808) = 500.9 \text{ lbf} \quad \text{Ans.}$$

$$(\Sigma M_C)_x = 0 \Rightarrow D_z = \frac{2.33}{6.13}(808) = 307.1 \text{ lbf} \quad \text{Ans.}$$

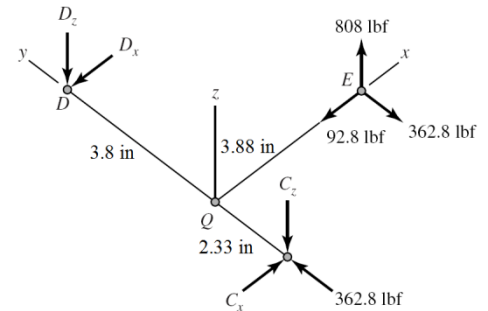

(b) For  $DQC$ , let  $x', y', z'$  correspond to the original  $-y, x, z$  axes.

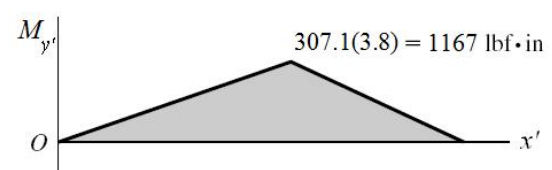
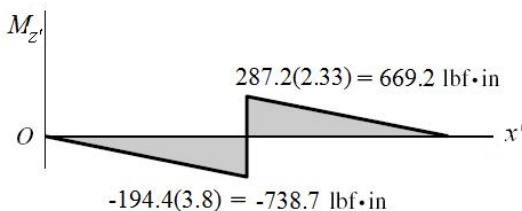
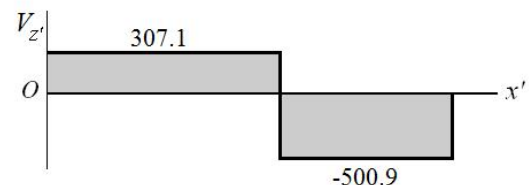
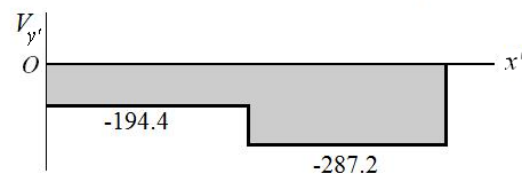
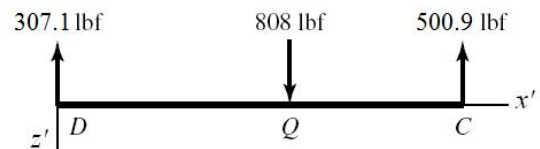
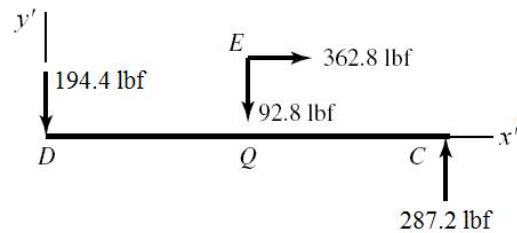

(c) The critical stress element is just to the right of  $Q$ , where the bending moment in both planes is maximum, and where the torsional and axial loads exist.

$$T = 808(3.88) = 3135 \text{ lbf} \cdot \text{in}$$

$$M = \sqrt{669.2^2 + 1167^2} = 1345 \text{ lbf} \cdot \text{in}$$

$$\tau = \frac{16T}{\pi d^3} = \frac{16(3135)}{\pi(1.13^3)} = 11070 \text{ psi} \quad \text{Ans.}$$

$$\sigma_b = \pm \frac{32M}{\pi d^3} = \pm \frac{32(1345)}{\pi(1.13^3)} = \pm 9495 \text{ psi} \quad \text{Ans.}$$

$$\sigma_a = -\frac{F}{A} = -\frac{362.8}{(\pi/4)(1.13^2)} = -362 \text{ psi} \quad \text{Ans.}$$

(d) The critical stress element will be where the bending stress and axial stress are both in compression.

$$\sigma_{\max} = -9495 - 362 = -9857 \text{ psi}$$

$$\tau_{\max} = \sqrt{\left(\frac{-9857}{2}\right)^2 + 11070^2} = 12118 \text{ psi} = 12.1 \text{ kpsi} \quad \text{Ans.}$$

$$\sigma_1, \sigma_2 = \frac{-9857}{2} \pm \sqrt{\left(\frac{-9857}{2}\right)^2 + 11070^2}$$

$$\sigma_1 = 7189 \text{ psi} = 7.19 \text{ kpsi} \quad \text{Ans.}$$

$$\sigma_2 = -17046 \text{ psi} = -17.0 \text{ kpsi} \quad \text{Ans.}$$

3-75

(a)

$$(\Sigma M_D)_z = 0$$

$$6.13C_x - 3.8(46.6) - 3.88(140) = 0$$

$$C_x = 117.5 \text{ lbf} \quad \text{Ans.}$$

$$(\Sigma M_C)_z = 0$$

$$-6.13D_x - 2.33(46.6) + 3.88(140) = 0$$

$$D_x = 70.9 \text{ lbf} \quad \text{Ans.}$$

$$(\Sigma M_D)_x = 0 \Rightarrow C_z = \frac{3.8}{6.13}(406) = 251.7 \text{ lbf} \quad \text{Ans.}$$

$$(\Sigma M_C)_x = 0 \Rightarrow D_z = \frac{2.33}{6.13}(406) = 154.3 \text{ lbf} \quad \text{Ans.}$$

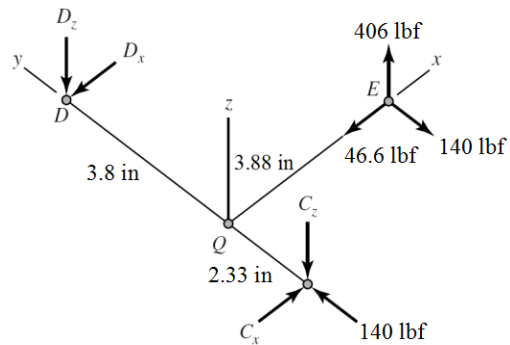

(b) For  $DQC$ , let  $x', y', z'$  correspond to the original  $-y, x, z$  axes.

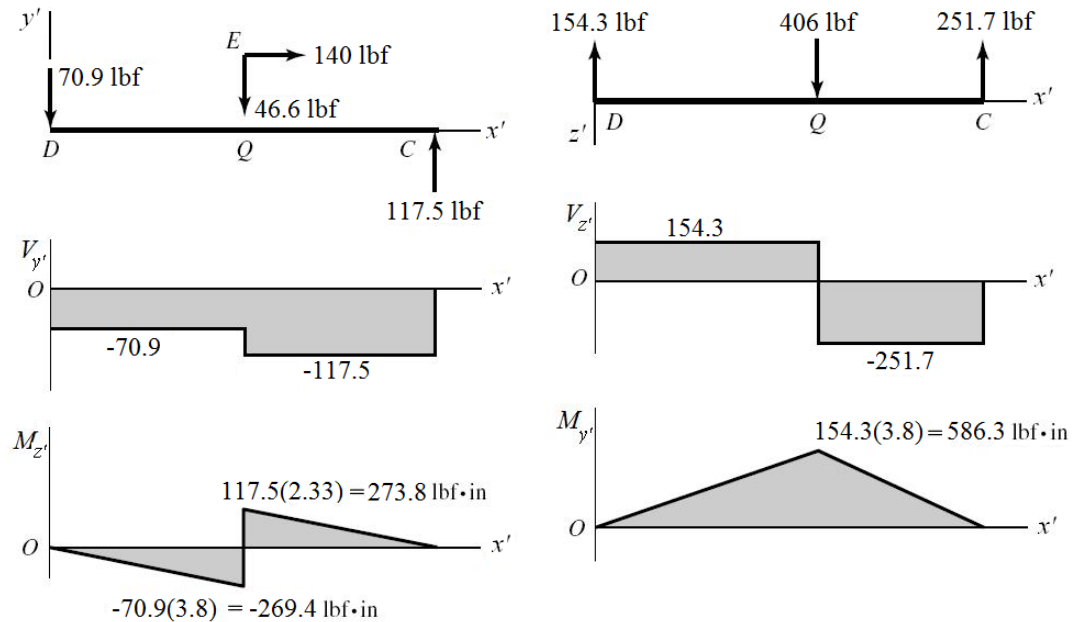

(c) The critical stress element is just to the right of  $Q$ , where the bending moment in both planes is maximum, and where the torsional and axial loads exist.

$$T = 406(3.88) = 1575 \text{ lbf} \cdot \text{in}$$

$$M = \sqrt{273.8^2 + 586.3^2} = 647.1 \text{ lbf} \cdot \text{in}$$

$$\tau = \frac{16T}{\pi d^3} = \frac{16(1575)}{\pi(1^3)} = 8021 \text{ psi} \quad \text{Ans.}$$

$$\sigma_b = \pm \frac{32M}{\pi d^3} = \pm \frac{32(647.1)}{\pi(1^3)} = \pm 6591 \text{ psi} \quad \text{Ans.}$$

$$\sigma_a = -\frac{F}{A} = -\frac{140}{(\pi/4)(1^2)} = -178.3 \text{ psi} \quad \text{Ans.}$$

(d) The critical stress element will be where the bending stress and axial stress are both in compression.

$$\sigma_{\max} = -6591 - 178.3 = -6769 \text{ psi}$$

$$\tau_{\max} = \sqrt{\left(\frac{-6769}{2}\right)^2 + 8021^2} = 8706 \text{ psi} = 8.71 \text{ kpsi} \quad \text{Ans.}$$

$$\sigma_1, \sigma_2 = \frac{-6769}{2} \pm \sqrt{\left(\frac{-6769}{2}\right)^2 + 8021^2}$$

$$\sigma_1 = 5321 \text{ psi} = 5.32 \text{ kpsi} \quad \text{Ans.}$$

$$\sigma_2 = -12090 \text{ psi} = -12.1 \text{ kpsi} \quad \text{Ans.}$$

**3-76**

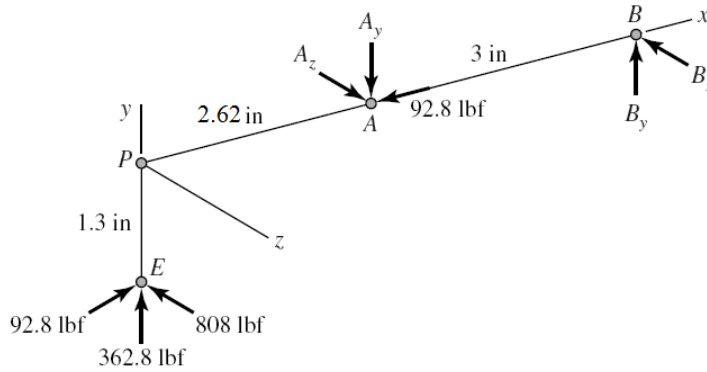

$$(\Sigma M_B)_z = -5.62(362.8) + 1.3(92.8) + 3A_y = 0$$

$$A_y = 639.4 \text{ lbf} \quad \text{Ans.}$$

$$(\Sigma M_A)_z = -2.62(362.8) + 1.3(92.8) + 3B_y = 0$$

$$B_y = 276.6 \text{ lbf} \quad \text{Ans.}$$

$$(\Sigma M_B)_y = 0 \Rightarrow A_z = \frac{5.62}{3}(808) = 1513.7 \text{ lbf} \quad \text{Ans.}$$

$$(\Sigma M_A)_y = 0 \Rightarrow B_z = \frac{2.62}{3}(808) = 705.7 \text{ lbf} \quad \text{Ans.}$$

**(b)**

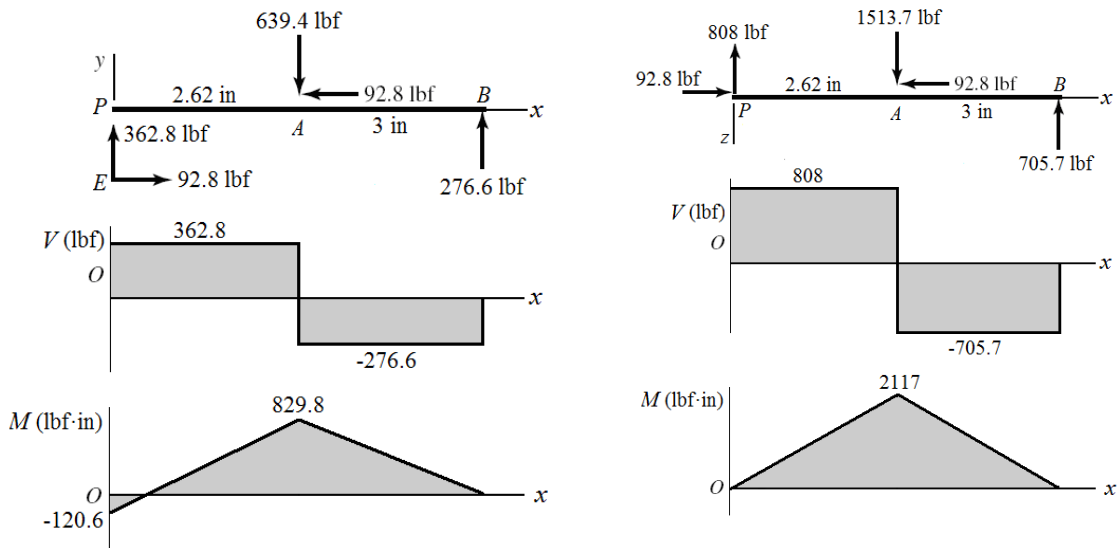

**(c)** The critical stress element is just to the left of *A*, where the bending moment in both planes is maximum, and where the torsional and axial loads exist.

$$T = 808(1.3) = 1050 \text{ lbf} \cdot \text{in}$$

$$\tau = \frac{16(1050)}{\pi(0.88^3)} = 7847 \text{ psi} \quad \text{Ans.}$$

$$M = \sqrt{(829.8)^2 + (2117)^2} = 2274 \text{ lbf} \cdot \text{in}$$

$$\sigma_b = \pm \frac{32M}{\pi d^3} = \pm \frac{32(2274)}{\pi(0.88^3)} = \pm 33\,990 \text{ psi} \quad \text{Ans.}$$

$$\sigma_a = -\frac{F}{A} = -\frac{92.8}{(\pi/4)(0.88^2)} = -153 \text{ psi} \quad \text{Ans.}$$

(d) The critical stress will occur when the bending stress and axial stress are both in compression.

$$\sigma_{\max} = -33\,990 - 153 = -34\,143 \text{ psi}$$

$$\tau_{\max} = \sqrt{\left(\frac{-34\,143}{2}\right)^2 + 7847^2} = 18\,789 \text{ psi} = 18.8 \text{ kpsi} \quad \text{Ans.}$$

$$\sigma_1, \sigma_2 = \frac{-34\,143}{2} \pm \sqrt{\left(\frac{-34\,143}{2}\right)^2 + 7847^2}$$

$$\sigma_1 = 1717 \text{ psi} = 1.72 \text{ kpsi} \quad \text{Ans.}$$

$$\sigma_2 = -35\,860 \text{ psi} = -35.9 \text{ kpsi} \quad \text{Ans.}$$

3-77

$$F_t = \frac{T}{c/2} = \frac{100}{0.125/2} = 1600 \text{ N}$$

$$F_n = 1600 \tan 20 = 582.4 \text{ N}$$

$$T_C = F_t (b/2) = 1600(0.250/2) = 200 \text{ N} \cdot \text{m}$$

$$P = \frac{T_C}{(a/2)} = \frac{200}{(0.150/2)} = 2667 \text{ N}$$

$$\sum (M_A)_z = 0$$

$$450R_{Dy} - 582.4(325) - 2667(75) = 0$$

$$R_{Dy} = 865.1 \text{ N}$$

$$\sum (M_A)_y = 0 = -450R_{Dz} + 1600(325) \Rightarrow R_{Dz} = 1156 \text{ N}$$

$$\sum F_y = 0 = R_{Ay} + 865.1 - 582.4 - 2667 \Rightarrow R_{Ay} = 2384 \text{ N}$$

$$\sum F_z = 0 = R_{Az} + 1156 - 1600 \Rightarrow R_{Az} = 444 \text{ N}$$

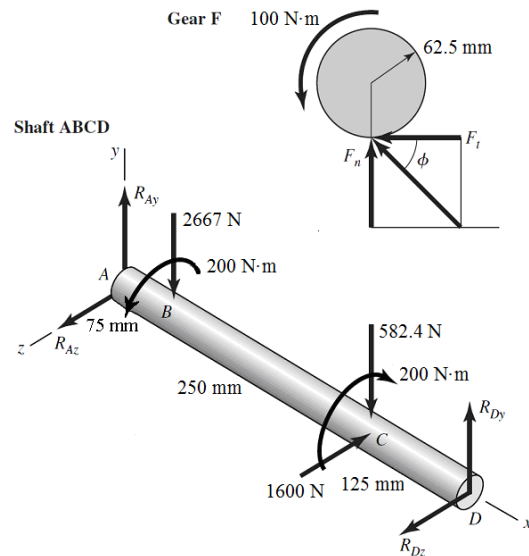

*AB* The maximum bending moment will either be at *B* or *C*. If this is not obvious, sketch the shear and bending moment diagrams. We will directly obtain the combined moments from each plane.

$$M_B = \overline{AB} \sqrt{R_{A_y}^2 + R_{A_z}^2} = 0.075 \sqrt{2384^2 + 444^2} = 181.9 \text{ N} \cdot \text{m}$$

$$M_C = \overline{CD} \sqrt{R_{D_y}^2 + R_{D_z}^2} = 0.125 \sqrt{865.1^2 + 1156^2} = 180.5 \text{ N} \cdot \text{m}$$

The stresses at *B* and *C* are almost identical, but the maximum stresses occur at *B*. *Ans.*

$$\sigma_B = \frac{32M_B}{\pi d^3} = \frac{32(181.9)}{\pi(0.030^3)} = 68.6(10^6) \text{ Pa} = 68.6 \text{ MPa}$$

$$\tau_B = \frac{16T_B}{\pi d^3} = \frac{16(200)}{\pi(0.030^3)} = 37.7(10^6) \text{ Pa} = 37.7 \text{ MPa}$$

$$\sigma_{\max} = \frac{\sigma_B}{2} + \sqrt{\left(\frac{\sigma_B}{2}\right)^2 + \tau_B^2} = \frac{68.6}{2} + \sqrt{\left(\frac{68.6}{2}\right)^2 + 37.7^2} = 85.3 \text{ MPa} \quad \text{Ans.}$$

$$\tau_{\max} = \sqrt{\left(\frac{\sigma_B}{2}\right)^2 + \tau_B^2} = \sqrt{\left(\frac{68.6}{2}\right)^2 + 37.7^2} = 51.0 \text{ MPa} \quad \text{Ans.}$$

**3-78**

$$F_t = \frac{T}{c/2} = \frac{100}{0.125/2} = 1600 \text{ N}$$

$$F_n = 1600 \tan 20 = 582.4 \text{ N}$$

$$T_C = F_t (b/2) = 1600(0.250/2) = 200 \text{ N} \cdot \text{m}$$

$$P = \frac{T_C}{(a/2)} = \frac{200}{(0.150/2)} = 2667 \text{ N}$$

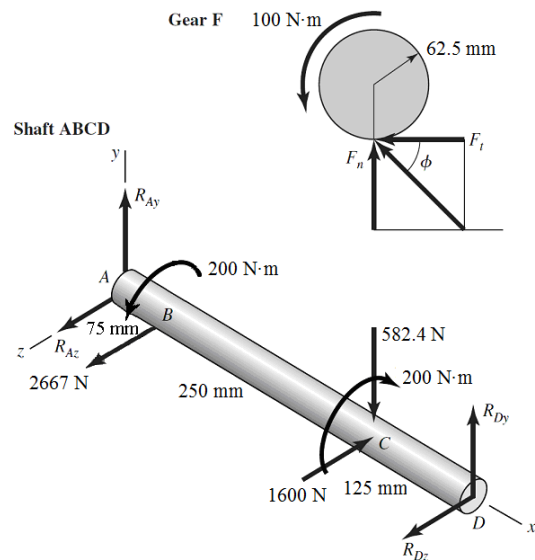

$$\sum (M_A)_z = 0 = 450R_{D_y} - 582.4(325) \quad \Rightarrow \quad R_{D_y} = 420.6 \text{ N}$$

$$\sum (M_A)_y = 0 = -450R_{D_z} + 1600(325) - 2667(75) \quad \Rightarrow \quad R_{D_z} = 711.1 \text{ N}$$

$$\sum F_y = 0 = R_{A_y} + 420.6 - 582.4 \quad \Rightarrow \quad R_{A_y} = 161.8 \text{ N}$$

$$\sum F_z = 0 = R_{A_z} + 711.1 - 1600 + 2667 \quad \Rightarrow \quad R_{A_z} = -1778 \text{ N}$$

The maximum bending moment will either be at  $B$  or  $C$ . If this is not obvious, sketch shear and bending moment diagrams. We will directly obtain the combined moments from each plane.

$$M_B = \overline{AB} \sqrt{R_{A_y}^2 + R_{A_z}^2} = 0.075 \sqrt{161.8^2 + (-1778)^2} = 133.9 \text{ N} \cdot \text{m}$$

$$M_C = \overline{CD} \sqrt{R_{D_y}^2 + R_{D_z}^2} = 0.125 \sqrt{420.6^2 + 711.1^2} = 103.3 \text{ N} \cdot \text{m}$$

The maximum stresses occur at  $B$ . *Ans.*

$$\sigma_B = \frac{32M_B}{\pi d^3} = \frac{32(133.9)}{\pi(0.030^3)} = 50.5(10^6) \text{ Pa} = 50.5 \text{ MPa}$$

$$\tau_B = \frac{16T_B}{\pi d^3} = \frac{16(200)}{\pi(0.030^3)} = 37.7(10^6) \text{ Pa} = 37.7 \text{ MPa}$$

$$\sigma_{\max} = \frac{\sigma_B}{2} + \sqrt{\left(\frac{\sigma_B}{2}\right)^2 + \tau_B^2} = \frac{50.5}{2} + \sqrt{\left(\frac{50.5}{2}\right)^2 + 37.7^2} = 70.6 \text{ MPa} \quad \textit{Ans.}$$

$$\tau_{\max} = \sqrt{\left(\frac{\sigma_B}{2}\right)^2 + \tau_B^2} = \sqrt{\left(\frac{50.5}{2}\right)^2 + 37.7^2} = 45.4 \text{ MPa} \quad \textit{Ans.}$$

### 3-79

$$F_t = \frac{T}{c/2} = \frac{900}{10/2} = 180 \text{ lbf}$$

$$F_n = 180 \tan 20 = 65.5 \text{ lbf}$$

$$T_C = F_t (b/2) = 180(5/2) = 450 \text{ lbf} \cdot \text{in}$$

$$P = \frac{T_C}{(a/2)} = \frac{450}{(6/2)} = 150 \text{ lbf}$$

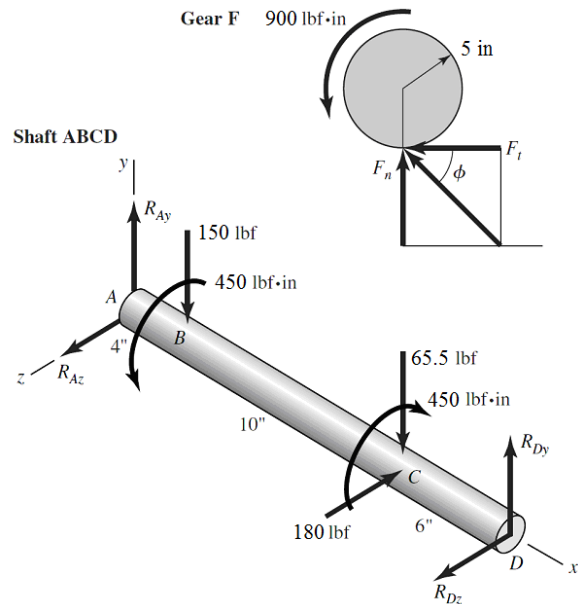

$$\sum (M_A)_z = 0 = 20R_{D_y} - 65.5(14) - 150(4) \Rightarrow R_{D_y} = 75.9 \text{ lbf}$$

$$\sum (M_A)_y = 0 = -20R_{D_z} + 180(14) \Rightarrow R_{D_z} = 126 \text{ lbf}$$

$$\sum F_y = 0 = R_{A_y} + 75.9 - 65.5 - 150 \Rightarrow R_{A_y} = 140 \text{ lbf}$$

$$\sum F_z = 0 = R_{A_z} + 126 - 180 \Rightarrow R_{A_z} = 54.0 \text{ lbf}$$

The maximum bending moment will either be at  $B$  or  $C$ . If this is not obvious, sketch shear and bending moment diagrams. We will directly obtain the combined moments from each plane.

$$M_B = \overline{AB} \sqrt{R_{A_y}^2 + R_{A_z}^2} = 4\sqrt{140^2 + 54^2} = 600 \text{ lbf} \cdot \text{in}$$

$$M_C = \overline{CD} \sqrt{R_{D_y}^2 + R_{D_z}^2} = 6\sqrt{75.9^2 + 126^2} = 883 \text{ lbf} \cdot \text{in}$$

The maximum stresses occur at  $C$ . *Ans.*

$$\sigma_C = \frac{32M_C}{\pi d^3} = \frac{32(883)}{\pi(1.375^3)} = 3460 \text{ psi}$$

$$\tau_C = \frac{16T_C}{\pi d^3} = \frac{16(450)}{\pi(1.375^3)} = 882 \text{ psi}$$

$$\sigma_{\max} = \frac{\sigma_C}{2} + \sqrt{\left(\frac{\sigma_C}{2}\right)^2 + \tau_C^2} = \frac{3460}{2} + \sqrt{\left(\frac{3460}{2}\right)^2 + 882^2} = 3670 \text{ psi} \quad \text{Ans.}$$

$$\tau_{\max} = \sqrt{\left(\frac{\sigma_C}{2}\right)^2 + \tau_C^2} = \sqrt{\left(\frac{3460}{2}\right)^2 + 882^2} = 1940 \text{ psi} \quad \text{Ans.}$$

### 3-80

(a) Rod  $AB$  experiences constant torsion throughout its length, and maximum bending moment at the wall. Both torsional shear stress and bending stress will be maximum on the outer surface. The transverse shear will be very small compared to bending and torsion, due to the reasonably high length to diameter ratio, so it will not dominate the determination of the critical location. The critical stress element will be at the wall, at either the top (compression) or the bottom (tension) on the  $y$  axis. We will select the bottom element for this analysis.

(b) Transverse shear is zero at the critical stress elements on the top and bottom surfaces.

$$\sigma_x = \frac{Mc}{I} = \frac{M(d/2)}{\pi d^4 / 64} = \frac{32M}{\pi d^3} = \frac{32(8)(200)}{\pi(1)^3} = 16\,297 \text{ psi} = 16.3 \text{ kpsi}$$

$$\tau_{xz} = \frac{Tr}{J} = \frac{T(d/2)}{\pi d^4 / 32} = \frac{16T}{\pi d^3} = \frac{16(5)(200)}{\pi(1)^3} = 5093 \text{ psi} = 5.09 \text{ kpsi}$$

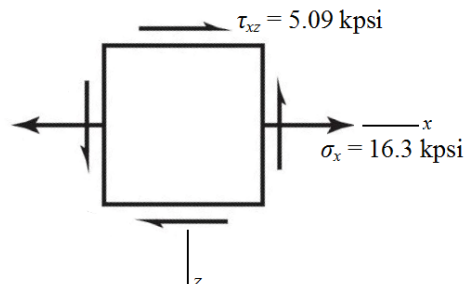



(c)

$$\sigma_1, \sigma_2 = \frac{\sigma_x}{2} \pm \sqrt{\left(\frac{\sigma_x}{2}\right)^2 + (\tau_{xz})^2} = \frac{16.3}{2} \pm \sqrt{\left(\frac{16.3}{2}\right)^2 + (5.09)^2}$$

$$\sigma_1 = 17.8 \text{ kpsi} \quad \text{Ans.}$$

$$\sigma_2 = -1.46 \text{ kpsi} \quad \text{Ans.}$$

$$\tau_{\max} = \sqrt{\left(\frac{\sigma_x}{2}\right)^2 + (\tau_{xz})^2} = \sqrt{\left(\frac{16.3}{2}\right)^2 + (5.09)^2} = 9.61 \text{ kpsi} \quad \text{Ans.}$$

### 3-81

(a) Rod  $AB$  experiences constant torsion throughout its length, and maximum bending moments at the wall in both planes of bending. Both torsional shear stress and bending stress will be maximum on the outer surface. The transverse shear will be very small compared to bending and torsion, due to the reasonably high length to diameter ratio, so it will not dominate the determination of the critical location. The critical stress element will be on the outer surface at the wall, with its critical location determined by the plane of the combined bending moments.

$$M_y = -(100)(8) = -800 \text{ lbf}\cdot\text{in}$$

$$M_z = (175)(8) = 1400 \text{ lbf}\cdot\text{in}$$

$$M_{\text{tot}} = \sqrt{M_y^2 + M_z^2} \\ = \sqrt{(-800)^2 + 1400^2} = 1612 \text{ lbf}\cdot\text{in}$$

$$\theta = \tan^{-1}\left(\left|\frac{M_y}{M_z}\right|\right) = \tan^{-1}\left(\frac{800}{1400}\right) = 29.7^\circ$$

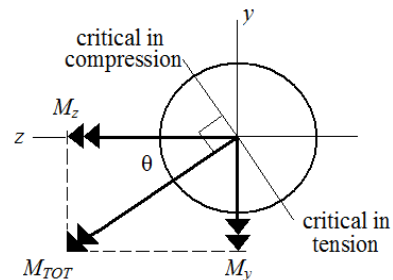

The combined bending moment vector is at an angle of  $29.7^\circ$  CCW from the  $z$  axis. The critical bending stress location, and thus the critical stress element, will be  $\pm 90^\circ$  from this vector, as shown. There are two equally critical stress elements, one in tension ( $119.7^\circ$  CCW from the  $z$  axis) and the other in compression ( $60.3^\circ$  CW from the  $z$  axis). We'll continue the analysis with the element in tension.

(b) Transverse shear is zero at the critical stress elements on the outer surfaces.

$$\sigma_x = \frac{M_{\text{tot}}c}{I} = \frac{M_{\text{tot}}(d/2)}{\pi d^4/64} = \frac{32M_{\text{tot}}}{\pi d^3} = \frac{32(1612)}{\pi(1)^3} = 16\,420 \text{ psi} = 16.4 \text{ kpsi}$$

$$\tau = \frac{Tr}{J} = \frac{T(d/2)}{\pi d^4/32} = \frac{16T}{\pi d^3} = \frac{16(5)(175)}{\pi(1)^3} = 4456 \text{ psi} = 4.46 \text{ kpsi}$$

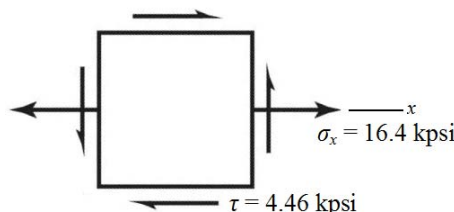

(c)

$$\sigma_1, \sigma_2 = \frac{\sigma_x}{2} \pm \sqrt{\left(\frac{\sigma_x}{2}\right)^2 + \tau^2} = \frac{16.4}{2} \pm \sqrt{\left(\frac{16.4}{2}\right)^2 + (4.46)^2}$$

$$\sigma_1 = 17.5 \text{ kpsi} \quad \text{Ans.}$$

$$\sigma_2 = -1.13 \text{ kpsi} \quad \text{Ans.}$$

$$\tau_{\max} = \sqrt{\left(\frac{\sigma_x}{2}\right)^2 + \tau^2} = \sqrt{\left(\frac{16.4}{2}\right)^2 + (4.46)^2} = 9.33 \text{ kpsi} \quad \text{Ans.}$$

### 3-82

(a) Rod *AB* experiences constant torsion and constant axial tension throughout its length, and maximum bending moments at the wall from both planes of bending. Both torsional shear stress and bending stress will be maximum on the outer surface. The transverse shear will be very small compared to bending and torsion, due to the reasonably high length to diameter ratio, so it will not dominate the determination of the critical location. The critical stress element will be on the outer surface at the wall, with its critical location determined by the plane of the combined bending moments.

$$M_y = -(100)(8) - (75)(5) = -1175 \text{ lbf}\cdot\text{in}$$

$$M_z = (-200)(8) = -1600 \text{ lbf}\cdot\text{in}$$

$$M_{\text{tot}} = \sqrt{M_y^2 + M_z^2}$$
$$= \sqrt{(-1175)^2 + (-1600)^2} = 1985 \text{ lbf}\cdot\text{in}$$

$$\theta = \tan^{-1}\left(\left|\frac{M_y}{M_z}\right|\right) = \tan^{-1}\left(\frac{1175}{1600}\right) = 36.3^\circ$$

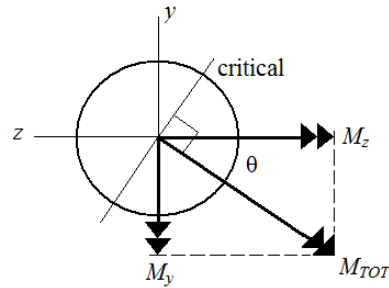

The combined bending moment vector is at an angle of  $36.3^\circ$  CW from the negative *z* axis. The critical bending stress location will be  $\pm 90^\circ$  from this vector, as shown. Since there is an axial stress in tension, the critical stress element will be where the bending is also in tension. The critical stress element is therefore on the outer surface at the wall, at an angle of  $36.3^\circ$  CW from the *y* axis.

(b) Transverse shear is zero at the critical stress element on the outer surface.

$$\sigma_{x,\text{bend}} = \frac{M_{\text{tot}}c}{I} = \frac{M_{\text{tot}}(d/2)}{\pi d^4/64} = \frac{32M_{\text{tot}}}{\pi d^3} = \frac{32(1985)}{\pi(1)^3} = 20220 \text{ psi} = 20.2 \text{ kpsi}$$

$$\sigma_{x,\text{axial}} = \frac{F_x}{A} = \frac{F_x}{\pi d^2/4} = \frac{75}{\pi(1)^2/4} = 95.5 \text{ psi} = 0.1 \text{ kpsi}, \text{ which is essentially negligible}$$

$$\sigma_x = \sigma_{x,\text{axial}} + \sigma_{x,\text{bend}} = 20220 + 95.5 = 20316 \text{ psi} = 20.3 \text{ kpsi}$$

$$\tau = \frac{Tr}{J} = \frac{16T}{\pi d^3} = \frac{16(5)(200)}{\pi(1)^3} = 5093 \text{ psi} = 5.09 \text{ kpsi}$$

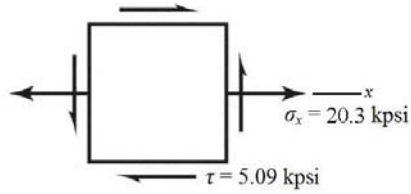

(c)

$$\sigma_1, \sigma_2 = \frac{\sigma_x}{2} \pm \sqrt{\left(\frac{\sigma_x}{2}\right)^2 + \tau^2} = \frac{20.3}{2} \pm \sqrt{\left(\frac{20.3}{2}\right)^2 + (5.09)^2}$$

$$\sigma_1 = 21.5 \text{ kpsi} \quad \text{Ans.}$$

$$\sigma_2 = -1.20 \text{ kpsi} \quad \text{Ans.}$$

$$\tau_{\max} = \sqrt{\left(\frac{\sigma_x}{2}\right)^2 + \tau^2} = \sqrt{\left(\frac{20.3}{2}\right)^2 + (5.09)^2} = 11.4 \text{ kpsi} \quad \text{Ans.}$$

**3-83**

$$T = (2)(200) = 400 \text{ lbf}\cdot\text{in}$$

The maximum shear stress due to torsion occurs in the middle of the longest side of the rectangular cross section. From the table on p. 102, with  $b/c = 1.5/0.25 = 6$ ,  $\alpha = 0.299$ . From Eq. (3-40),

$$\tau_{\max} = \frac{T}{\alpha bc^2} = \frac{400}{(0.299)(1.5)(0.25)^2} = 14\,270 \text{ psi} = 14.3 \text{ kpsi} \quad \text{Ans.}$$

**3-84**

(a) The cross section at  $A$  will experience bending, torsion, and transverse shear. Both torsional shear stress and bending stress will be maximum on the outer surface. The transverse shear will be very small compared to bending and torsion, due to the reasonably high length to diameter ratio, so it will not dominate the determination of the critical location. The critical stress element will be at either the top (compression) or the bottom (tension) on the  $y$  axis. We'll select the bottom element for this analysis.

(b) Transverse shear is zero at the critical stress elements on the top and bottom surfaces.

$$\sigma_x = \frac{Mc}{I} = \frac{M(d/2)}{\pi d^4/64} = \frac{32M}{\pi d^3} = \frac{32(11)(250)}{\pi(1)^3} = 28\,011 \text{ psi} = 28.0 \text{ kpsi}$$

$$\tau_{xz} = \frac{Tr}{J} = \frac{T(d/2)}{\pi d^4/32} = \frac{16T}{\pi d^3} = \frac{16(12)(250)}{\pi(1)^3} = 15\,279 \text{ psi} = 15.3 \text{ kpsi}$$

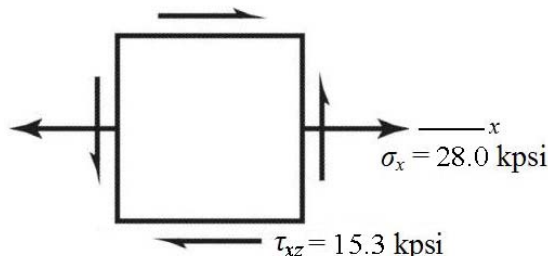

(c)

$$\sigma_1, \sigma_2 = \frac{\sigma_x}{2} \pm \sqrt{\left(\frac{\sigma_x}{2}\right)^2 + (\tau_{xz})^2} = \frac{28.0}{2} \pm \sqrt{\left(\frac{28.0}{2}\right)^2 + (15.3)^2}$$

$$\sigma_1 = 34.7 \text{ kpsi} \quad \text{Ans.}$$

$$\sigma_2 = -6.7 \text{ kpsi} \quad \text{Ans.}$$

$$\tau_{\max} = \sqrt{\left(\frac{\sigma_x}{2}\right)^2 + (\tau_{xz})^2} = \sqrt{\left(\frac{28.0}{2}\right)^2 + (15.3)^2} = 20.7 \text{ kpsi} \quad \text{Ans.}$$

### 3-85

(a) The cross section at *A* will experience bending, torsion, axial, and transverse shear. Both torsional shear stress and bending stress will be maximum on the outer surface. The transverse shear will be very small compared to bending and torsion, due to the reasonably high length to diameter ratio, so it will not dominate the determination of the critical location. The critical stress element will be on the outer surface, with its critical location determined by the plane of the combined bending moments.

$$M_y = (300)(12) = 3600 \text{ lbf}\cdot\text{in}$$

$$M_z = (250)(11) = 2750 \text{ lbf}\cdot\text{in}$$

$$M_{\text{tot}} = \sqrt{M_y^2 + M_z^2} \\ = \sqrt{(3600)^2 + (2750)^2} = 4530 \text{ lbf}\cdot\text{in}$$

$$\theta = \tan^{-1}\left(\frac{M_z}{M_y}\right) = \tan^{-1}\left(\frac{2750}{3600}\right) = 37.4^\circ$$

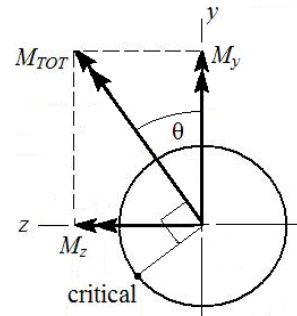

The combined bending moment vector is at an angle of  $37.4^\circ$  CCW from the *y* axis. The critical bending stress location will be  $90^\circ$  CCW from this vector, where the tensile bending stress is additive with the tensile axial stress. The critical stress element is therefore on the outer surface, at an angle of  $37.4^\circ$  CCW from the *z* axis.

(b)

$$\sigma_{x,\text{bend}} = \frac{M_{\text{tot}} c}{I} = \frac{M_{\text{tot}} (d/2)}{\pi d^4 / 64} = \frac{32 M_{\text{tot}}}{\pi d^3} = \frac{32(4530)}{\pi(1)^3} = 46\,142 \text{ psi} = 46.1 \text{ kpsi}$$

$$\sigma_{x,\text{axial}} = \frac{F_x}{A} = \frac{F_x}{\pi d^2 / 4} = \frac{300}{\pi(1)^2 / 4} = 382 \text{ psi} = 0.382 \text{ kpsi}$$

$$\sigma_x = \sigma_{x,\text{axial}} + \sigma_{x,\text{bend}} = 46\,142 + 382 = 46\,524 \text{ psi} = 46.5 \text{ kpsi}$$

$$\tau = \frac{Tr}{J} = \frac{16T}{\pi d^3} = \frac{16(12)(250)}{\pi(1)^3} = 15\,279 \text{ psi} = 15.3 \text{ kpsi}$$

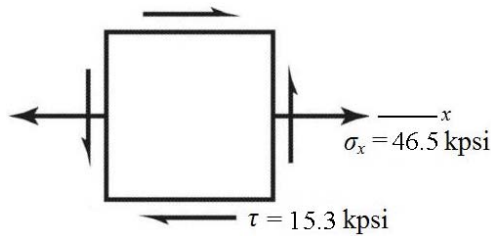

(c)

$$\sigma_1, \sigma_2 = \frac{\sigma_x}{2} \pm \sqrt{\left(\frac{\sigma_x}{2}\right)^2 + \tau^2} = \frac{46.5}{2} \pm \sqrt{\left(\frac{46.5}{2}\right)^2 + (15.3)^2}$$

$$\sigma_1 = 51.1 \text{ kpsi} \quad \text{Ans.}$$

$$\sigma_2 = -4.58 \text{ kpsi} \quad \text{Ans.}$$

$$\tau_{\max} = \sqrt{\left(\frac{\sigma_x}{2}\right)^2 + \tau^2} = \sqrt{\left(\frac{46.5}{2}\right)^2 + (15.3)^2} = 27.8 \text{ kpsi} \quad \text{Ans.}$$

### 3-86

(a) The cross section at  $A$  will experience bending, torsion, axial, and transverse shear. Both torsional shear stress and bending stress will be maximum on the outer surface. The transverse shear will be very small compared to bending and torsion, due to the reasonably high length to diameter ratio, so it will not dominate the determination of the critical location. The critical stress element will be on the outer surface, with its critical location determined by the plane of the combined bending moments.

$$M_y = (300)(12) - (-100)(11) = 4700 \text{ lbf}\cdot\text{in}$$

$$M_z = (250)(11) = 2750 \text{ lbf}\cdot\text{in}$$

$$M_{\text{tot}} = \sqrt{M_y^2 + M_z^2} \\ = \sqrt{(4700)^2 + (2750)^2} = 5445 \text{ lbf}\cdot\text{in}$$

$$\theta = \tan^{-1}\left(\frac{M_z}{M_y}\right) = \tan^{-1}\left(\frac{2750}{4700}\right) = 30.3^\circ$$

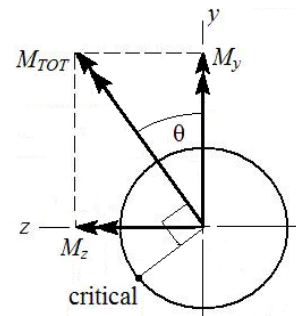

The combined bending moment vector is at an angle of  $30.3^\circ$  CCW from the  $y$  axis. The critical bending stress location will be  $90^\circ$  CCW from this vector, where the tensile bending stress is additive with the tensile axial stress. The critical stress element is therefore on the outer surface, at an angle of  $30.3^\circ$  CCW from the  $z$  axis.

(b)

$$\sigma_{x,\text{bend}} = \frac{M_{\text{tot}} c}{I} = \frac{M_{\text{tot}} (d/2)}{\pi d^4 / 64} = \frac{32 M_{\text{tot}}}{\pi d^3} = \frac{32(5445)}{\pi(1)^3} = 55\,462 \text{ psi} = 55.5 \text{ kpsi}$$

$$\sigma_{x,\text{axial}} = \frac{F_x}{A} = \frac{F_x}{\pi d^2 / 4} = \frac{300}{\pi(1)^2 / 4} = 382 \text{ psi} = 0.382 \text{ kpsi}$$

$$\sigma_x = \sigma_{x,\text{axial}} + \sigma_{x,\text{bend}} = 55\,462 + 382 = 55\,844 \text{ psi} = 55.8 \text{ kpsi}$$

$$\tau = \frac{Tr}{J} = \frac{16T}{\pi d^3} = \frac{16(12)(250)}{\pi(1)^3} = 15\,279 \text{ psi} = 15.3 \text{ kpsi}$$

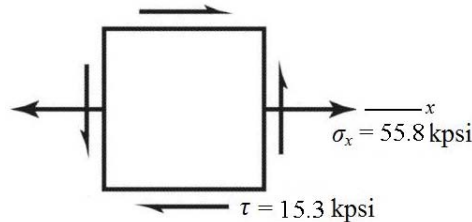

(c)

$$\sigma_1, \sigma_2 = \frac{\sigma_x}{2} \pm \sqrt{\left(\frac{\sigma_x}{2}\right)^2 + \tau^2} = \frac{55.8}{2} \pm \sqrt{\left(\frac{55.8}{2}\right)^2 + (15.3)^2}$$

$$\sigma_1 = 59.7 \text{ kpsi} \quad \text{Ans.}$$

$$\sigma_2 = -3.92 \text{ kpsi} \quad \text{Ans.}$$

$$\tau_{\max} = \sqrt{\left(\frac{\sigma_x}{2}\right)^2 + \tau^2} = \sqrt{\left(\frac{55.8}{2}\right)^2 + (15.3)^2} = 31.8 \text{ kpsi} \quad \text{Ans.}$$

### 3-87

(a) The cross section at  $A$  will experience bending, torsion, and transverse shear. Both torsional shear stress and bending stress will be maximum on the outer surface, where the stress concentration will also be applicable. The transverse shear will be very small compared to bending and torsion, due to the reasonably high length to diameter ratio, so it will not dominate the determination of the critical location. The critical stress element will be at either the top (compression) or the bottom (tension) on the  $y$  axis. We'll select the bottom element for this analysis.

(b) Transverse shear is zero at the critical stress elements on the top and bottom surfaces.

$$r/d = 0.125/1 = 0.125$$

$$D/d = 1.5/1 = 1.5$$

$$K_{t,\text{torsion}} = 1.39 \quad \text{Fig. A-15-8}$$

$$K_{t,\text{bend}} = 1.59 \quad \text{Fig. A-15-9}$$

$$\sigma_x = K_{t,\text{bend}} \frac{Mc}{I} = K_{t,\text{bend}} \frac{32M}{\pi d^3} = (1.59) \frac{32(11)(250)}{\pi(1)^3} = 44\,538 \text{ psi} = 44.5 \text{ kpsi}$$

$$\tau_{xz} = K_{t,\text{torsion}} \frac{Tr}{J} = K_{t,\text{torsion}} \frac{16T}{\pi d^3} = (1.39) \frac{16(12)(250)}{\pi(1)^3} = 21\,238 \text{ psi} = 21.2 \text{ kpsi}$$

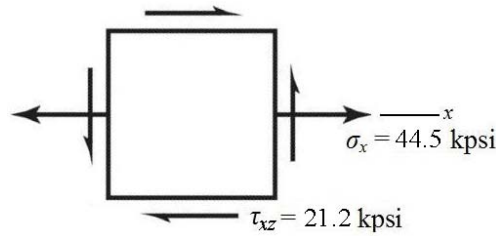

(c)

$$\sigma_1, \sigma_2 = \frac{\sigma_x}{2} \pm \sqrt{\left(\frac{\sigma_x}{2}\right)^2 + (\tau_{xz})^2} = \frac{44.5}{2} \pm \sqrt{\left(\frac{44.5}{2}\right)^2 + (21.2)^2}$$

$$\sigma_1 = 53.0 \text{ kpsi} \quad \text{Ans.}$$

$$\sigma_2 = -8.48 \text{ kpsi} \quad \text{Ans.}$$

$$\tau_{\max} = \sqrt{\left(\frac{\sigma_x}{2}\right)^2 + (\tau_{xz})^2} = \sqrt{\left(\frac{44.5}{2}\right)^2 + (21.2)^2} = 30.7 \text{ kpsi} \quad \text{Ans.}$$

### 3-88

(a) The cross section at  $A$  will experience bending, torsion, axial, and transverse shear. Both torsional shear stress and bending stress will be maximum on the outer surface, where the stress concentration will also be applicable. The transverse shear will be very small compared to bending and torsion, due to the reasonably high length to diameter ratio, so it will not dominate the determination of the critical location. The critical stress element will be on the outer surface, with its critical location determined by the plane of the combined bending moments.

$$M_y = (300)(12) = 3600 \text{ lbf}\cdot\text{in}$$

$$M_z = (250)(11) = 2750 \text{ lbf}\cdot\text{in}$$

$$M_{\text{tot}} = \sqrt{M_y^2 + M_z^2}$$

$$= \sqrt{(3600)^2 + (2750)^2} = 4530 \text{ lbf}\cdot\text{in}$$

$$\theta = \tan^{-1}\left(\left|\frac{M_z}{M_y}\right|\right) = \tan^{-1}\left(\frac{2750}{3600}\right) = 37.4^\circ$$

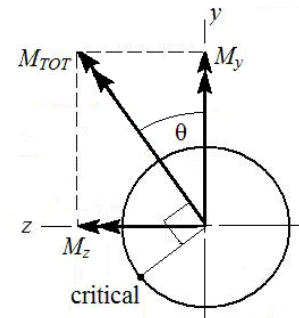

The combined bending moment vector is at an angle of  $37.4^\circ$  CCW from the  $y$  axis. The critical bending stress location will be  $90^\circ$  CCW from this vector, where the tensile bending stress is additive with the tensile axial stress. The critical stress element is therefore on the outer surface, at an angle of  $37.4^\circ$  CCW from the  $z$  axis.

(b)

$$r/d = 0.125/1 = 0.125$$

$$D/d = 1.5/1 = 1.5$$

$$K_{t,axial} = 1.75 \quad \text{Fig. A-15-7}$$

$$K_{t,torsion} = 1.39 \quad \text{Fig. A-15-8}$$

$$K_{t,bend} = 1.59 \quad \text{Fig. A-15-9}$$

$$\sigma_{x,\text{bend}} = K_{t,\text{bend}} \frac{Mc}{I} = K_{t,\text{bend}} \frac{32M}{\pi d^3} = (1.59) \frac{32(4530)}{\pi(1)^3} = 73\,366 \text{ psi} = 73.4 \text{ kpsi}$$

$$\sigma_{x,\text{axial}} = K_{t,\text{axial}} \frac{F_x}{A} = (1.75) \frac{300}{\pi(1)^2/4} = 668 \text{ psi} = 0.668 \text{ kpsi}$$

$$\sigma_x = \sigma_{x,\text{axial}} + \sigma_{x,\text{bend}} = 73\,366 + 668 = 74\,034 \text{ psi} = 74.0 \text{ kpsi}$$

$$\tau = K_{t,\text{torsion}} \frac{Tr}{J} = K_{t,\text{torsion}} \frac{16T}{\pi d^3} = (1.39) \frac{16(12)(250)}{\pi(1)^3} = 21\,238 \text{ psi} = 21.2 \text{ kpsi}$$

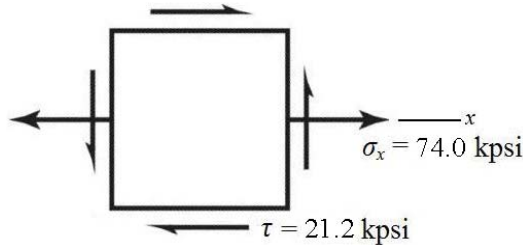

(c)

$$\sigma_1, \sigma_2 = \frac{\sigma_x}{2} \pm \sqrt{\left(\frac{\sigma_x}{2}\right)^2 + \tau^2} = \frac{74.0}{2} \pm \sqrt{\left(\frac{74.0}{2}\right)^2 + (21.2)^2}$$

$$\sigma_1 = 79.6 \text{ kpsi} \quad \text{Ans.}$$

$$\sigma_2 = -5.64 \text{ kpsi} \quad \text{Ans.}$$

$$\tau_{\text{max}} = \sqrt{\left(\frac{\sigma_x}{2}\right)^2 + \tau^2} = \sqrt{\left(\frac{74.0}{2}\right)^2 + (21.2)^2} = 42.6 \text{ kpsi} \quad \text{Ans.}$$

### 3-89

(a) The cross section at  $A$  will experience bending, torsion, axial, and transverse shear. Both torsional shear stress and bending stress will be maximum on the outer surface, where the stress concentration is also applicable. The transverse shear will be very small compared to bending and torsion, due to the reasonably high length to diameter ratio, so it will not dominate the determination of the critical location. The critical stress element will be on the outer surface, with its critical location determined by the plane of the combined bending moments.

$$M_y = (300)(12) - (-100)(11) = 4700 \text{ lbf}\cdot\text{in}$$

$$M_z = (250)(11) = 2750 \text{ lbf}\cdot\text{in}$$

$$M_{\text{tot}} = \sqrt{M_y^2 + M_z^2} \\ = \sqrt{(4700)^2 + (2750)^2} = 5445 \text{ lbf}\cdot\text{in}$$

$$\theta = \tan^{-1}\left(\frac{M_z}{M_y}\right) = \tan^{-1}\left(\frac{2750}{4700}\right) = 30.3^\circ$$

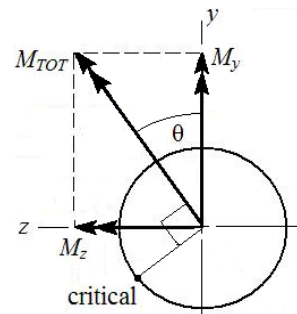



The combined bending moment vector is at an angle of 30.3° CCW from the y axis. The critical bending stress location will be 90° CCW from this vector, where the tensile bending stress is additive with the tensile axial stress. The critical stress element is therefore on the outer surface, at an angle of 30.3° CCW from the z axis.

(b)

$$r/d = 0.125/1 = 0.125$$

$$D/d = 1.5/1 = 1.5$$

$$K_{t,axial} = 1.75 \quad \text{Fig. A-15-7}$$

$$K_{t,torsion} = 1.39 \quad \text{Fig. A-15-8}$$

$$K_{t,bend} = 1.59 \quad \text{Fig. A-15-9}$$

$$\sigma_{x,bend} = K_{t,bend} \frac{Mc}{I} = K_{t,bend} \frac{32M}{\pi d^3} = (1.59) \frac{32(5445)}{\pi(1)^3} = 88\,185 \text{ psi} = 88.2 \text{ kpsi}$$

$$\sigma_{x,axial} = K_{t,axial} \frac{F_x}{A} = (1.75) \frac{300}{\pi(1)^2/4} = 668 \text{ psi} = 0.668 \text{ kpsi}$$

$$\sigma_x = \sigma_{x,axial} + \sigma_{x,bend} = 88\,185 + 668 = 88\,853 \text{ psi} = 88.9 \text{ kpsi}$$

$$\tau = K_{t,torsion} \frac{Tr}{J} = K_{t,torsion} \frac{16T}{\pi d^3} = (1.39) \frac{16(12)(250)}{\pi(1)^3} = 21\,238 \text{ psi} = 21.2 \text{ kpsi}$$

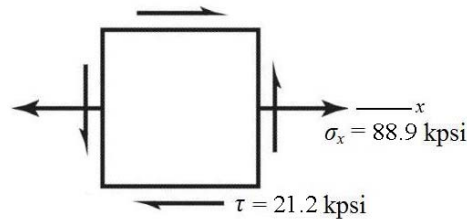

(c)

$$\sigma_1, \sigma_2 = \frac{\sigma_x}{2} \pm \sqrt{\left(\frac{\sigma_x}{2}\right)^2 + \tau^2} = \frac{88.9}{2} \pm \sqrt{\left(\frac{88.9}{2}\right)^2 + (21.2)^2}$$

$$\sigma_1 = 93.7 \text{ kpsi} \quad \text{Ans.}$$

$$\sigma_2 = -4.80 \text{ kpsi} \quad \text{Ans.}$$

$$\tau_{\max} = \sqrt{\left(\frac{\sigma_x}{2}\right)^2 + \tau^2} = \sqrt{\left(\frac{88.9}{2}\right)^2 + (21.2)^2} = 49.2 \text{ kpsi} \quad \text{Ans.}$$

### 3-90

(a)  $M = F(p/4)$ ,  $c = p/4$ ,  $I = bh^3/12$ ,  $b = \pi d_r n_t$ ,  $h = p/2$

$$\sigma_b = \pm \frac{Mc}{I} = \pm \frac{[F(p/4)](p/4)}{bh^3/12} = \pm \frac{Fp^2}{16(\pi d_r n_t)(p/2)^3/12}$$

$$\sigma_b = \pm \frac{6F}{\pi d_r n_t p} \quad \text{Ans.}$$

$$(b) \sigma_a = -\frac{F}{A} = -\frac{F}{\pi d_r^2/4} = -\frac{4F}{\pi d_r^2} \quad \text{Ans.}$$

$$\tau_t = \frac{Tr}{J} = \frac{T(d_r/2)}{\pi d_r^4/32} = \frac{16T}{\pi d_r^3} \quad \text{Ans.}$$

(c) The bending stress causes compression in the  $x$  direction. The axial stress causes compression in the  $y$  direction. The torsional stress shears across the  $y$  face in the negative  $z$  direction.

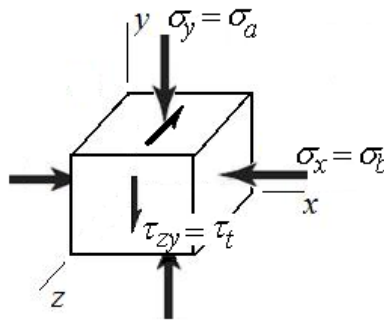

(d) Analyze the stress element from part (c) using the equations developed in parts (a) and (b).  
 $d_r = d - p = 1.5 - 0.25 = 1.25$  in

$$\sigma_x = \sigma_b = -\frac{6F}{\pi d_r n_t p} = -\frac{6(1500)}{\pi(1.25)(2)(0.25)} = -4584 \text{ psi} = -4.584 \text{ kpsi}$$

$$\sigma_y = \sigma_a = -\frac{4F}{\pi d_r^2} = -\frac{4(1500)}{\pi(1.25^2)} = -1222 \text{ psi} = -1.222 \text{ kpsi}$$

$$\tau_{yz} = -\tau_t = -\frac{16T}{\pi d_r^3} = -\frac{16(235)}{\pi(1.25^3)} = -612.8 \text{ psi} = -0.6128 \text{ kpsi}$$

Use Eq. (3-15) for the three-dimensional stress element.

$$\sigma^3 - (-4.584 - 1.222)\sigma^2 + [(-4.584)(-1.222) - (-0.6128)^2]\sigma - [(-4.584)(-0.6128)^2] = 0$$

$$\sigma^3 + 5.806\sigma^2 + 5.226\sigma - 1.721 = 0$$

The roots are at 0.2543, -4.584, and -1.476. Thus, the ordered principal stresses are

$$\sigma_1 = 0.2543 \text{ kpsi}, \sigma_2 = -1.476 \text{ kpsi}, \text{ and } \sigma_3 = -4.584 \text{ kpsi.} \quad \text{Ans.}$$

From Eq. (3-16), the principal shear stresses are

$$\tau_{1/2} = \frac{\sigma_1 - \sigma_2}{2} = \frac{0.2543 - (-1.476)}{2} = 0.8652 \text{ kpsi} \quad \text{Ans.}$$

$$\tau_{2/3} = \frac{\sigma_2 - \sigma_3}{2} = \frac{(-1.476) - (-4.584)}{2} = 1.554 \text{ kpsi} \quad \text{Ans.}$$

$$\tau_{1/3} = \frac{\sigma_1 - \sigma_3}{2} = \frac{0.2543 - (-4.584)}{2} = 2.419 \text{ kpsi} \quad \text{Ans.}$$

---

**3-91** As shown in Fig. 3-32, the maximum stresses occur at the inside fiber where  $r = r_i$ . Therefore, from Eq. (3-50)

$$\begin{aligned} \sigma_{t,\max} &= \frac{r_i^2 p_i}{r_o^2 - r_i^2} \left( 1 + \frac{r_o^2}{r_i^2} \right) \\ &= p_i \left( \frac{r_o^2 + r_i^2}{r_o^2 - r_i^2} \right) \quad \text{Ans.} \end{aligned}$$

$$\sigma_{r,\max} = \frac{r_i^2 p_i}{r_o^2 - r_i^2} \left( 1 - \frac{r_o^2}{r_i^2} \right) = -p_i \quad \text{Ans.}$$

---

**3-92** If  $p_i = 0$ , Eq. (3-49) becomes

$$\begin{aligned} \sigma_t &= \frac{-p_o r_o^2 - r_i^2 r_o^2 p_o / r^2}{r_o^2 - r_i^2} \\ &= -\frac{p_o r_o^2}{r_o^2 - r_i^2} \left( 1 + \frac{r_i^2}{r^2} \right) \end{aligned}$$

The maximum tangential stress occurs at  $r = r_i$ . So

$$\sigma_{t,\max} = -\frac{2p_o r_o^2}{r_o^2 - r_i^2} \quad \text{Ans.}$$

For  $\sigma_r$ , we have

$$\begin{aligned} \sigma_r &= \frac{-p_o r_o^2 - r_i^2 r_o^2 p_o / r^2}{r_o^2 - r_i^2} \\ &= \frac{p_o r_o^2}{r_o^2 - r_i^2} \left( \frac{r_i^2}{r^2} - 1 \right) \end{aligned}$$

So  $\sigma_r = 0$  at  $r = r_i$ . Thus at  $r = r_o$

$$\sigma_{r,\max} = \frac{p_o r_o^2}{r_o^2 - r_i^2} \left( \frac{r_i^2 - r_o^2}{r_o^2} \right) = -p_o \quad \text{Ans.}$$

---

**3-93** The force due to the pressure on half of the sphere is resisted by the stress that is distributed around the center plane of the sphere. All planes are the same, so

$$(\sigma_t)_{\text{av}} = \sigma_1 = \sigma_2 = \frac{p(\pi/4)d_i^2}{\pi d_i t} = \frac{pd_i}{4t} \quad \text{Ans.}$$

The radial stress on the inner surface of the shell is,  $\sigma_3 = -p$  Ans.

---

**3-94**  $\sigma_t > \sigma_l > \sigma_r$

$$\tau_{\text{max}} = (\sigma_t - \sigma_r)/2 \text{ at } r = r_i$$

$$\tau_{\text{max}} = \frac{1}{2} \left[ \frac{r_i^2 p_i}{r_o^2 - r_i^2} \left( 1 + \frac{r_o^2}{r_i^2} \right) - \frac{r_i^2 p_i}{r_o^2 - r_i^2} \left( 1 - \frac{r_o^2}{r_i^2} \right) \right] = \frac{r_o^2 p_i}{r_o^2 - r_i^2}$$

$$\Rightarrow p_i = \frac{r_o^2 - r_i^2}{r_o^2} \tau_{\text{max}} = \frac{3^2 - 2.75^2}{3^2} (10\,000) = 1597 \text{ psi} \quad \text{Ans.}$$

---

**3-95**  $\sigma_t > \sigma_l > \sigma_r$

$$\tau_{\text{max}} = (\sigma_t - \sigma_r)/2 \text{ at } r = r_i$$

$$\tau_{\text{max}} = \frac{1}{2} \left[ \frac{r_i^2 p_i}{r_o^2 - r_i^2} \left( 1 + \frac{r_o^2}{r_i^2} \right) - \frac{r_i^2 p_i}{r_o^2 - r_i^2} \left( 1 - \frac{r_o^2}{r_i^2} \right) \right] = \frac{r_i^2 p_i}{r_o^2 - r_i^2} \left( \frac{r_o^2}{r_i^2} \right) = \frac{r_o^2 p_i}{r_o^2 - r_i^2}$$

$$\Rightarrow r_i = r_o \sqrt{\frac{(\tau_{\text{max}} - p_i)}{\tau_{\text{max}}}} = 100 \sqrt{\frac{(25 - 4)10^6}{25(10^6)}} = 91.7 \text{ mm}$$

$$t = r_o - r_i = 100 - 91.7 = 8.3 \text{ mm} \quad \text{Ans.}$$

---

**3-96**  $\sigma_t > \sigma_l > \sigma_r$

$$\tau_{\text{max}} = (\sigma_t - \sigma_r)/2 \text{ at } r = r_i$$

$$\tau_{\text{max}} = \frac{1}{2} \left[ \frac{r_i^2 p_i}{r_o^2 - r_i^2} \left( 1 + \frac{r_o^2}{r_i^2} \right) - \frac{r_i^2 p_i}{r_o^2 - r_i^2} \left( 1 - \frac{r_o^2}{r_i^2} \right) \right] = \frac{r_i^2 p_i}{r_o^2 - r_i^2} \left( \frac{r_o^2}{r_i^2} \right) = \frac{r_o^2 p_i}{r_o^2 - r_i^2}$$

$$= \frac{4^2(500)}{4^2 - 3.75^2} = 4129 \text{ psi} \quad \text{Ans.}$$

---

**3-97** From Eq. (3-49) with  $p_i = 0$ ,

$$\sigma_t = -\frac{r_o^2 p_o}{r_o^2 - r_i^2} \left( 1 + \frac{r_i^2}{r^2} \right)$$

$$\sigma_r = -\frac{r_o^2 p_o}{r_o^2 - r_i^2} \left( 1 - \frac{r_i^2}{r^2} \right)$$

$\sigma_t > \sigma_l > \sigma_r$ , and since  $\sigma_t$  and  $\sigma_r$  are negative,

$$\tau_{\max} = (\sigma_r - \sigma_t)/2 \text{ at } r = r_o$$

$$\tau_{\max} = \frac{1}{2} \left[ -\frac{r_o^2 p_o}{r_o^2 - r_i^2} \left( 1 - \frac{r_i^2}{r_o^2} \right) + \frac{r_o^2 p_o}{r_o^2 - r_i^2} \left( 1 + \frac{r_i^2}{r_o^2} \right) \right] = \frac{r_o^2 p_o}{r_o^2 - r_i^2} \left( \frac{r_i^2}{r_o^2} \right) = \frac{r_i^2 p_o}{r_o^2 - r_i^2}$$

$$\Rightarrow p_o = \frac{r_o^2 - r_i^2}{r_i^2} \tau_{\max} = \frac{3^2 - 2.75^2}{2.75^2} (10\,000) = 1900 \text{ psi} \quad \text{Ans.}$$

**3-98** From Eq. (3-49) with  $p_i = 0$ ,

$$\sigma_t = -\frac{r_o^2 p_o}{r_o^2 - r_i^2} \left( 1 + \frac{r_i^2}{r^2} \right)$$

$$\sigma_r = -\frac{r_o^2 p_o}{r_o^2 - r_i^2} \left( 1 - \frac{r_i^2}{r^2} \right)$$

$\sigma_t > \sigma_l > \sigma_r$ , and since  $\sigma_t$  and  $\sigma_r$  are negative,

$$\tau_{\max} = (\sigma_r - \sigma_t)/2 \text{ at } r = r_o$$

$$\tau_{\max} = \frac{1}{2} \left[ -\frac{r_o^2 p_o}{r_o^2 - r_i^2} \left( 1 - \frac{r_i^2}{r_o^2} \right) + \frac{r_o^2 p_o}{r_o^2 - r_i^2} \left( 1 + \frac{r_i^2}{r_o^2} \right) \right] = \frac{r_o^2 p_o}{r_o^2 - r_i^2} \left( \frac{r_i^2}{r_o^2} \right) = \frac{r_i^2 p_o}{r_o^2 - r_i^2}$$

$$\Rightarrow r_i = r_o \sqrt{\frac{\tau_{\max}}{(\tau_{\max} + p_o)}} = 100 \sqrt{\frac{25(10^6)}{(25 + 4)10^6}} = 92.8 \text{ mm}$$

$$t = r_o - r_i = 100 - 92.8 = 7.2 \text{ mm} \quad \text{Ans.}$$

**3-99** From Eq. (3-49) with  $p_i = 0$ ,

$$\sigma_t = -\frac{r_o^2 p_o}{r_o^2 - r_i^2} \left( 1 + \frac{r_i^2}{r^2} \right)$$

$$\sigma_r = -\frac{r_o^2 p_o}{r_o^2 - r_i^2} \left( 1 - \frac{r_i^2}{r^2} \right)$$

$\sigma_t > \sigma_l > \sigma_r$ , and since  $\sigma_t$  and  $\sigma_r$  are negative,

$$\tau_{\max} = (\sigma_r - \sigma_t)/2 \text{ at } r = r_o$$

$$\tau_{\max} = \frac{1}{2} \left[ -\frac{r_o^2 p_o}{r_o^2 - r_i^2} \left( 1 - \frac{r_i^2}{r_o^2} \right) + \frac{r_o^2 p_o}{r_o^2 - r_i^2} \left( 1 + \frac{r_i^2}{r_o^2} \right) \right] = \frac{r_o^2 p_o}{r_o^2 - r_i^2} \left( \frac{r_i^2}{r_o^2} \right) = \frac{r_i^2 p_o}{r_o^2 - r_i^2}$$

$$= \frac{3.75^2 (500)}{4^2 - 3.75^2} = 3629 \text{ psi } \textit{Ans.}$$

---

**3-100** From Table A-20,  $S_y = 490 \text{ MPa}$   
From Eq. (3-49) with  $p_i = 0$ ,

$$\sigma_t = -\frac{r_o^2 p_o}{r_o^2 - r_i^2} \left( 1 + \frac{r_i^2}{r^2} \right)$$

Maximum will occur at  $r = r_i$

$$\sigma_{t,\max} = -\frac{2r_o^2 p_o}{r_o^2 - r_i^2} \Rightarrow p_o = -\frac{\sigma_{t,\max} (r_o^2 - r_i^2)}{2r_o^2} = -\frac{[0.8(-490)](25^2 - 19^2)}{2(25^2)} = 82.8 \text{ MPa } \textit{Ans.}$$

---

**3-101** From Table A-20,  $S_y = 71 \text{ kpsi}$   
From Eq. (3-49) with  $p_i = 0$ ,

$$\sigma_t = -\frac{r_o^2 p_o}{r_o^2 - r_i^2} \left( 1 + \frac{r_i^2}{r^2} \right)$$

Maximum will occur at  $r = r_i$

$$\sigma_{t,\max} = -\frac{2r_o^2 p_o}{r_o^2 - r_i^2} \Rightarrow p_o = -\frac{\sigma_{t,\max} (r_o^2 - r_i^2)}{2r_o^2} = -\frac{[0.8(-71)](1^2 - 0.75^2)}{2(1^2)} = 12.4 \text{ kpsi } \textit{Ans.}$$

---

**3-102** From Table A-20,  $S_y = 490 \text{ MPa}$   
From Eq. (3-50)

$$\sigma_t = \frac{r_i^2 p_i}{r_o^2 - r_i^2} \left( 1 + \frac{r_o^2}{r^2} \right)$$

Maximum will occur at  $r = r_i$

$$\sigma_{t,\max} = \frac{r_i^2 p_i}{r_o^2 - r_i^2} \left( 1 + \frac{r_o^2}{r_i^2} \right) = \frac{p_i (r_o^2 + r_i^2)}{r_o^2 - r_i^2}$$

$$\Rightarrow p_i = \frac{\sigma_{t,\max} (r_o^2 - r_i^2)}{r_o^2 + r_i^2} = \frac{[0.8(490)](25^2 - 19^2)}{(25^2 + 19^2)} = 105 \text{ MPa } \textit{Ans.}$$

---

**3-103** From Table A-20,  $S_y = 71$  MPa  
From Eq. (3-50)

$$\sigma_t = \frac{r_i^2 p_i}{r_o^2 - r_i^2} \left( 1 + \frac{r_o^2}{r^2} \right)$$

Maximum will occur at  $r = r_i$

$$\begin{aligned} \sigma_{t,\max} &= \frac{r_i^2 p_i}{r_o^2 - r_i^2} \left( 1 + \frac{r_o^2}{r_i^2} \right) = \frac{p_i (r_o^2 + r_i^2)}{r_o^2 - r_i^2} \\ \Rightarrow p_i &= \frac{\sigma_{t,\max} (r_o^2 - r_i^2)}{r_o^2 + r_i^2} = \frac{[0.8(71)](1^2 - 0.75^2)}{(1^2 + 0.75^2)} = 15.9 \text{ ksi } \textit{Ans.} \end{aligned}$$

**3-104** The longitudinal stress will be due to the weight of the vessel above the maximum stress point. From Table A-5, the unit weight of steel is  $\gamma_s = 0.282$  lbf/in<sup>3</sup>. The area of the wall is

$$A_{\text{wall}} = (\pi/4)(360^2 - 358.5^2) = 846.5 \text{ in}^2$$

The volume of the wall and dome are

$$V_{\text{wall}} = A_{\text{wall}} h = 846.5 (720) = 609.5 (10^3) \text{ in}^3$$

$$V_{\text{dome}} = (2\pi/3)(180^3 - 179.25^3) = 152.0 (10^3) \text{ in}^3$$

The weight of the structure on the wall area at the tank bottom is

$$\begin{aligned} W &= \gamma_s V_{\text{total}} = 0.282(609.5 + 152.0) (10^3) = 214.7(10^3) \text{ lbf} \\ \sigma_t &= -\frac{W}{A_{\text{wall}}} = -\frac{214.7(10^3)}{846.5} = -254 \text{ psi} \end{aligned}$$

The maximum pressure will occur at the bottom of the tank,  $p_i = \gamma_{\text{water}} h$ . From Eq. (3-50) with  $r = r_i$

$$\begin{aligned} \sigma_t &= \frac{r_i^2 p_i}{r_o^2 - r_i^2} \left( 1 + \frac{r_o^2}{r_i^2} \right) = p_i \left( \frac{r_o^2 + r_i^2}{r_o^2 - r_i^2} \right) \\ &= \left[ 62.4(55) \left( \frac{1 \text{ ft}^2}{144 \text{ in}^2} \right) \right] \left( \frac{180^2 + 179.25^2}{180^2 - 179.25^2} \right) = 5708 \doteq 5710 \text{ psi } \textit{Ans.} \\ \sigma_r &= \frac{r_i^2 p_i}{r_o^2 - r_i^2} \left( 1 - \frac{r_o^2}{r_i^2} \right) = -p_i = -62.4(55) \left( \frac{1 \text{ ft}^2}{144 \text{ in}^2} \right) = -23.8 \text{ psi } \textit{Ans.} \end{aligned}$$

Note: These stresses are very idealized as the floor of the tank will restrict the values calculated.

Since  $\sigma_1 \geq \sigma_2 \geq \sigma_3$ ,  $\sigma_1 = \sigma_t = 5708$  psi,  $\sigma_2 = \sigma_r = -24$  psi and  $\sigma_3 = \sigma_l = -254$  psi.  
From Eq. (3-16),

$$\tau_{1/3} = \frac{5708 + 254}{2} = 2981 \doteq 2980 \text{ psi}$$

$$\tau_{1/2} = \frac{5708 + 24}{2} = 2866 \doteq 2870 \text{ psi} \quad \text{Ans.}$$

$$\tau_{2/3} = \frac{-24 + 254}{2} = 115 \text{ psi}$$

**3-105** Stresses from additional pressure are,  
Eq. (3-51),

$$(\sigma_t)_{50\text{psi}} = \frac{50(179.25^2)}{180^2 - 179.25^2} = 5963 \text{ psi}$$

$$(\sigma_r)_{50\text{psi}} = -50 \text{ psi}$$

Eq. (3-50)

$$(\sigma_t)_{50\text{psi}} = 50 \frac{180^2 + 179.25^2}{180^2 - 179.25^2} = 11\,975 \text{ psi}$$

Adding these to the stresses found in Prob. 3-104 gives

$$\sigma_t = 5708 + 11\,975 = 17\,683 \text{ psi} = 17.7 \text{ kpsi} \quad \text{Ans.}$$

$$\sigma_r = -23.8 - 50 = -73.8 \text{ psi} \quad \text{Ans.}$$

$$\sigma_l = -254 + 5963 = 5709 \text{ psi} \quad \text{Ans.}$$

Note: These stresses are very idealized as the floor of the tank will restrict the values calculated.

From Eq. (3-16)

$$\tau_{1/3} = \frac{17\,683 + 73.8}{2} = 8879 \text{ psi}$$

$$\tau_{1/2} = \frac{17\,683 - 5709}{2} = 5987 \text{ psi} \quad \text{Ans.}$$

$$\tau_{2/3} = \frac{5709 + 23.8}{2} = 2866 \text{ psi}$$

**3-106** Since  $\sigma_t$  and  $\sigma_r$  are both positive and  $\sigma_t > \sigma_r$

$$\tau_{\max} = (\sigma_t)_{\max} / 2$$

From Eq. (3-55),  $\sigma_t$  is maximum at  $r = r_i = 0.3125$  in. The term



$$\rho\omega^2\left(\frac{3+\nu}{8}\right) = \frac{0.282}{386}\left[\frac{2\pi(5000)}{60}\right]^2\left(\frac{3+0.292}{8}\right) = 82.42 \text{ lbf/in}$$

$$(\sigma_t)_{\max} = 82.42\left[0.3125^2 + 2.75^2 + \frac{(0.3125^2)(2.75^2)}{0.3125^2} - \frac{1+3(0.292)}{3+0.292}(0.3125^2)\right]$$

$$= 1260 \text{ psi}$$

$$\tau_{\max} = \frac{1260}{2} = 630 \text{ psi} \quad \text{Ans.}$$

Radial stress:

$$\sigma_r = k\left(r_i^2 + r_o^2 - \frac{r_i^2 r_o^2}{r^2} - r^2\right)$$

Maxima:

$$\frac{d\sigma_r}{dr} = k\left(2\frac{r_i^2 r_o^2}{r^3} - 2r\right) = 0 \Rightarrow r = \sqrt{r_i r_o} = \sqrt{0.3125(2.75)} = 0.927 \text{ in}$$

$$(\sigma_r)_{\max} = 82.42\left[0.3125^2 + 2.75^2 - \frac{0.3125^2(2.75^2)}{0.927^2} - 0.927^2\right]$$

$$= 490 \text{ psi} \quad \text{Ans.}$$

**3-107**  $\omega = 2\pi(2000)/60 = 209.4 \text{ rad/s}$ ,  $\rho = 3320 \text{ kg/m}^3$ ,  $\nu = 0.24$ ,  $r_i = 0.01 \text{ m}$ ,  $r_o = 0.125 \text{ m}$

Using Eq. (3-55)

$$\sigma_t = 3320(209.4)^2\left(\frac{3+0.24}{8}\right)\left[(0.01)^2 + (0.125)^2 + (0.125)^2 - \frac{1+3(0.24)}{3+0.24}(0.01)^2\right](10)^{-6}$$

$$= 1.85 \text{ MPa} \quad \text{Ans.}$$

**3-108**  $\omega = 2\pi(12\,000)/60 = 1256.6 \text{ rad/s}$ ,

$$\rho = \frac{(5/16)}{386(1/16)(\pi/4)(5^2 - 0.75^2)} = 6.749(10^{-4}) \text{ lbf}\cdot\text{s}^2 / \text{in}^4$$

The maximum shear stress occurs at bore where  $\tau_{\max} = \sigma_t / 2$ . From Eq. (3-55)

$$(\sigma_t)_{\max} = 6.749(10^{-4})(1256.6)^2\left(\frac{3+0.20}{8}\right)\left[0.375^2 + 2.5^2 + 2.5^2 - \frac{1+3(0.20)}{3+0.20}(0.375)^2\right]$$

$$= 5360 \text{ psi}$$

$$\tau_{\max} = 5360 / 2 = 2680 \text{ psi} \quad \text{Ans.}$$

**3-109**  $\omega = 2\pi(3500)/60 = 366.5 \text{ rad/s}$ ,  
 mass of blade =  $m = \rho V = (0.282 / 386) [1.25(30)(0.125)] = 3.425(10^{-3}) \text{ lbf}\cdot\text{s}^2/\text{in}$

$$F = (m/2) \omega^2 r$$

$$= [3.425(10^{-3})/2](366.5^2)(7.5)$$

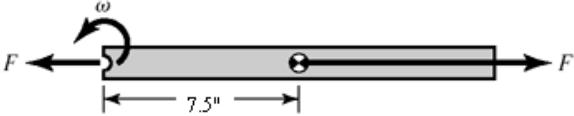
$$= 1725 \text{ lbf}$$

$$A_{\text{nom}} = (1.25 - 0.5)(1/8) = 0.09375 \text{ in}^2$$

$$\sigma_{\text{nom}} = F / A_{\text{nom}} = 1725 / 0.09375 = 18400 \text{ psi} \quad \text{Ans.}$$

Note: Stress concentration Fig. A-15-1 gives  $K_t = 2.25$  which increases  $\sigma_{\max}$  and fatigue.

**3-110**  $\nu = 0.292$ ,  $E = 207 \text{ GPa}$ ,  $r_i = 0$ ,  $R = 25 \text{ mm}$ ,  $r_o = 50 \text{ mm}$

Eq. (3-57),

$$p = \frac{207(10^9)\delta}{2(0.025)^3} \left[ \frac{(0.05^2 - 0.025^2)(0.025^2 - 0)}{(0.05^2 - 0)} \right] (10^{-9}) = 3.105(10^3)\delta \quad (1)$$

where  $p$  is in MPa and  $\delta$  is in mm.

Maximum interference,

$$\delta_{\max} = \frac{1}{2}[50.042 - 50.000] = 0.021 \text{ mm} \quad \text{Ans.}$$

Minimum interference,

$$\delta_{\min} = \frac{1}{2}[50.026 - 50.025] = 0.0005 \text{ mm} \quad \text{Ans.}$$

From Eq. (1)

$$p_{\max} = 3.105(10^3)(0.021) = 65.2 \text{ MPa} \quad \text{Ans.}$$

$$p_{\min} = 3.105(10^3)(0.0005) = 1.55 \text{ MPa} \quad \text{Ans.}$$

**3-111**  $\nu = 0.292$ ,  $E = 30 \text{ Mpsi}$ ,  $r_i = 0$ ,  $R = 1 \text{ in}$ ,  $r_o = 2 \text{ in}$

Eq. (3-57),

$$p = \frac{30(10^6)\delta}{2(1^3)} \left[ \frac{(2^2 - 1^2)(1^2 - 0)}{(2^2 - 0)} \right] = 1.125(10^7)\delta \quad (1)$$

where  $p$  is in psi and  $\delta$  is in inches.

Maximum interference,

$$\delta_{\max} = \frac{1}{2}[2.0016 - 2.0000] = 0.0008 \text{ in} \quad \text{Ans.}$$

Minimum interference,

$$\delta_{\min} = \frac{1}{2}[2.0010 - 2.0010] = 0 \quad \text{Ans.}$$

From Eq. (1),

$$p_{\max} = 1.125(10^7)(0.0008) = 9\,000 \text{ psi} \quad \text{Ans.}$$

$$p_{\min} = 1.125(10^7)(0) = 0 \quad \text{Ans.}$$

**3-112**  $\nu = 0.292$ ,  $E = 207 \text{ GPa}$ ,  $r_i = 0$ ,  $R = 25 \text{ mm}$ ,  $r_o = 50 \text{ mm}$

Eq. (3-57),

$$p = \frac{207(10^9)\delta}{2(0.025)^3} \left[ \frac{(0.05^2 - 0.025^2)(0.025^2 - 0)}{(0.05^2 - 0)} \right] (10^{-9}) = 3.105(10^3)\delta \quad (1)$$

where  $p$  is in MPa and  $\delta$  is in mm.

Maximum interference,

$$\delta_{\max} = \frac{1}{2}[50.059 - 50.000] = 0.0295 \text{ mm} \quad \text{Ans.}$$

Minimum interference,

$$\delta_{\min} = \frac{1}{2}[50.043 - 50.025] = 0.009 \text{ mm} \quad \text{Ans.}$$

From Eq. (1)

$$p_{\max} = 3.105(10^3)(0.0295) = 91.6 \text{ MPa} \quad \text{Ans.}$$

$$p_{\min} = 3.105(10^3)(0.009) = 27.9 \text{ MPa} \quad \text{Ans.}$$

**3-113**  $\nu = 0.292$ ,  $E = 30 \text{ Mpsi}$ ,  $r_i = 0$ ,  $R = 1 \text{ in}$ ,  $r_o = 2 \text{ in}$

Eq. (3-57),

$$p = \frac{30(10^6)\delta}{2(1^3)} \left[ \frac{(2^2 - 1^2)(1^2 - 0)}{(2^2 - 0)} \right] = 1.125(10^7)\delta \quad (1)$$

where  $p$  is in psi and  $\delta$  is in inches.

Maximum interference,

$$\delta_{\max} = \frac{1}{2}[2.0023 - 2.0000] = 0.00115 \text{ in} \quad \text{Ans.}$$

Minimum interference,

$$\delta_{\min} = \frac{1}{2}[2.0017 - 2.0010] = 0.00035 \quad \text{Ans.}$$

From Eq. (1),

$$p_{\max} = 1.125(10^7)(0.00115) = 12\,940 \text{ psi} \quad \text{Ans.}$$

$$p_{\min} = 1.125(10^7)(0.00035) = 3\,938 \quad \text{Ans.}$$

**3-114**  $\nu = 0.292$ ,  $E = 207 \text{ GPa}$ ,  $r_i = 0$ ,  $R = 25 \text{ mm}$ ,  $r_o = 50 \text{ mm}$

Eq. (3-57),

$$p = \frac{207(10^9)\delta}{2(0.025)^3} \left[ \frac{(0.05^2 - 0.025^2)(0.025^2 - 0)}{(0.05^2 - 0)} \right] (10^{-9}) = 3.105(10^3)\delta \quad (1)$$

where  $p$  is in MPa and  $\delta$  is in mm.

Maximum interference,

$$\delta_{\max} = \frac{1}{2}[50.086 - 50.000] = 0.043 \text{ mm} \quad \text{Ans.}$$

Minimum interference,

$$\delta_{\min} = \frac{1}{2}[50.070 - 50.025] = 0.0225 \text{ mm} \quad \text{Ans.}$$

From Eq. (1)

$$p_{\max} = 3.105(10^3)(0.043) = 134 \text{ MPa} \quad \text{Ans.}$$

$$p_{\min} = 3.105(10^3)(0.0225) = 69.9 \text{ MPa} \quad \text{Ans.}$$

**3-115**  $\nu = 0.292$ ,  $E = 30 \text{ Mpsi}$ ,  $r_i = 0$ ,  $R = 1 \text{ in}$ ,  $r_o = 2 \text{ in}$

Eq. (3-57),

$$p = \frac{30(10^6)\delta}{2(1^3)} \left[ \frac{(2^2 - 1^2)(1^2 - 0)}{(2^2 - 0)} \right] = 1.125(10^7)\delta \quad (1)$$

where  $p$  is in psi and  $\delta$  is in inches.

Maximum interference,

$$\delta_{\max} = \frac{1}{2}[2.0034 - 2.0000] = 0.0017 \text{ in} \quad \text{Ans.}$$

Minimum interference,

$$\delta_{\min} = \frac{1}{2}[2.0028 - 2.0010] = 0.0009 \quad \text{Ans.}$$

From Eq. (1),

$$p_{\max} = 1.125(10^7)(0.0017) = 19\,130 \text{ psi} \quad \text{Ans.}$$

$$p_{\min} = 1.125(10^7)(0.0009) = 10\,130 \quad \text{Ans.}$$

**3-116** From Table A-5,  $E_i = E_o = 30 \text{ Mpsi}$ ,  $\nu_i = \nu_o = 0.292$ .  $r_i = 0$ ,  $R = 1 \text{ in}$ ,  $r_o = 1.5 \text{ in}$

The radial interference is  $\delta = \frac{1}{2}(2.002 - 2.000) = 0.001 \text{ in} \quad \text{Ans.}$

Eq. (3-57),

$$p = \frac{E\delta}{2R^3} \left[ \frac{(r_o^2 - R^2)(R^2 - r_i^2)}{r_o^2 - r_i^2} \right] = \frac{30(10^6)0.001}{2(1^3)} \left[ \frac{(1.5^2 - 1^2)(1^2 - 0)}{(1.5^2 - 0)} \right]$$

$$= 8333 \text{ psi} \doteq 8.33 \text{ kpsi} \quad \text{Ans.}$$

The tangential stresses at the interface for the inner and outer members are given by Eqs. (3-58) and (3-59), respectively.

$$(\sigma_t)_i|_{r=R} = -p \frac{R^2 + r_i^2}{R^2 - r_i^2} = -(8333) \frac{1^2 + 0^2}{1^2 - 0^2} = -8333 \text{ psi} \doteq -8.33 \text{ kpsi} \quad \text{Ans.}$$

$$(\sigma_t)_o|_{r=R} = p \frac{r_o^2 + R^2}{r_o^2 - R^2} = (8333) \frac{1.5^2 + 1^2}{1.5^2 - 1^2} = 21\,670 \text{ psi} \doteq 21.7 \text{ kpsi} \quad \text{Ans.}$$

**3-117** From Table A-5,  $E_i = 30 \text{ Mpsi}$ ,  $E_o = 14.5 \text{ Mpsi}$ ,  $\nu_i = 0.292$ ,  $\nu_o = 0.211$ .

$r_i = 0$ ,  $R = 1 \text{ in}$ ,  $r_o = 1.5 \text{ in}$

The radial interference is  $\delta = \frac{1}{2}(2.002 - 2.000) = 0.001 \text{ in} \quad \text{Ans.}$

Eq. (3-56),

$$p = \frac{\delta}{R \left[ \frac{1}{E_o} \left( \frac{r_o^2 + R^2}{r_o^2 - R^2} + \nu_o \right) + \frac{1}{E_i} \left( \frac{R^2 + r_i^2}{R^2 - r_i^2} - \nu_i \right) \right]}$$

$$p = \frac{0.001}{1 \left[ \frac{1}{14.5(10^6)} \left( \frac{1.5^2 + 1^2}{1.5^2 - 1^2} + 0.211 \right) + \frac{1}{30(10^6)} \left( \frac{1^2 + 0^2}{1^2 - 0^2} - 0.292 \right) \right]} = 4599 \text{ psi} \quad \text{Ans.}$$

The tangential stresses at the interface for the inner and outer members are given by Eqs. (3-58) and (3-59), respectively.

$$(\sigma_t)_i|_{r=R} = -p \frac{R^2 + r_i^2}{R^2 - r_i^2} = -(4599) \frac{1^2 + 0^2}{1^2 - 0^2} = -4599 \text{ psi} \quad \text{Ans.}$$

$$(\sigma_t)_o|_{r=R} = p \frac{r_o^2 + R^2}{r_o^2 - R^2} = (4599) \frac{1.5^2 + 1^2}{1.5^2 - 1^2} = 11\,960 \text{ psi} \quad \text{Ans.}$$

---

**3-118** From Table A-5,  $E_i = E_o = 30 \text{ Mpsi}$ ,  $\nu_i = \nu_o = 0.292$ .  $r_i = 0$ ,  $R = 0.5 \text{ in}$ ,  $r_o = 1 \text{ in}$   
The minimum and maximum radial interferences are

$$\delta_{\min} = \frac{1}{2}(1.002 - 1.002) = 0.000 \text{ in} \quad \text{Ans.}$$

$$\delta_{\max} = \frac{1}{2}(1.003 - 1.001) = 0.001 \text{ in} \quad \text{Ans.}$$

Since the minimum interference is zero, the minimum pressure and tangential stresses are zero. *Ans.*

The maximum pressure is obtained from Eq. (3-57).

$$p = \frac{E\delta}{2R^3} \left[ \frac{(r_o^2 - R^2)(R^2 - r_i^2)}{r_o^2 - r_i^2} \right]$$

$$p = \frac{30(10^6)0.001}{2(0.5^3)} \left[ \frac{(1^2 - 0.5^2)(0.5^2 - 0)}{(1^2 - 0)} \right] = 22\,500 \text{ psi} \quad \text{Ans}$$

The maximum tangential stresses at the interface for the inner and outer members are given by Eqs. (3-58) and (3-59), respectively.

$$(\sigma_t)_i|_{r=R} = -p \frac{R^2 + r_i^2}{R^2 - r_i^2} = -(22\,500) \frac{0.5^2 + 0^2}{0.5^2 - 0^2} = -22\,500 \text{ psi} \quad \text{Ans.}$$

$$(\sigma_t)_o|_{r=R} = p \frac{r_o^2 + R^2}{r_o^2 - R^2} = (22\,500) \frac{1^2 + 0.5^2}{1^2 - 0.5^2} = 37\,500 \text{ psi} \quad \text{Ans.}$$

---

**3-119** From Table A-5,  $E_i = 10.4 \text{ Mpsi}$ ,  $E_o = 30 \text{ Mpsi}$ ,  $\nu_i = 0.333$ ,  $\nu_o = 0.292$ .  
 $r_i = 0$ ,  $R = 1 \text{ in}$ ,  $r_o = 1.5 \text{ in}$

The minimum and maximum radial interferences are

$$\delta_{\min} = \frac{1}{2}[2.003 - 2.002] = 0.0005 \text{ in} \quad \text{Ans.}$$

$$\delta_{\max} = \frac{1}{2}[2.006 - 2.000] = 0.003 \text{ in} \quad \text{Ans.}$$

Eq. (3-56),

$$p = \frac{\delta}{R \left[ \frac{1}{E_o} \left( \frac{r_o^2 + R^2}{r_o^2 - R^2} + \nu_o \right) + \frac{1}{E_i} \left( \frac{R^2 + r_i^2}{R^2 - r_i^2} - \nu_i \right) \right]}$$

$$p = \frac{\delta}{1 \left[ \frac{1}{30(10^6)} \left( \frac{1.5^2 + 1^2}{1.5^2 - 1^2} + 0.292 \right) + \frac{1}{10.4(10^6)} \left( \frac{1^2 + 0^2}{1^2 - 0^2} - 0.333 \right) \right]}$$

$$p = 6.229(10^6) \delta \text{ psi} \quad \text{Ans.}$$

$$p_{\min} = 6.229(10^6) \delta_{\min} = 6.229(10^6)(0.0005) = 3114.6 \text{ psi} = 3.11 \text{ kpsi} \quad \text{Ans.}$$

$$p_{\max} = 6.229(10^6) \delta_{\max} = 6.229(10^6)(0.003) = 18\,687 \text{ psi} = 18.7 \text{ kpsi} \quad \text{Ans.}$$

The tangential stresses at the interface for the inner and outer members are given by Eqs. (3-58) and (3-59), respectively.

Minimum interference:

$$(\sigma_t)_i|_{\min} = -p_{\min} \frac{R^2 + r_i^2}{R^2 - r_i^2} = -(3.11) \frac{1^2 + 0^2}{1^2 - 0^2} = -3.11 \text{ kpsi} \quad \text{Ans.}$$

$$(\sigma_t)_o|_{\min} = p_{\min} \frac{r_o^2 + R^2}{r_o^2 - R^2} = (3.11) \frac{1.5^2 + 1^2}{1.5^2 - 1^2} = 8.09 \text{ kpsi} \quad \text{Ans.}$$

Maximum interference:

$$(\sigma_t)_i|_{\max} = -p_{\max} \frac{R^2 + r_i^2}{R^2 - r_i^2} = -(18.7) \frac{1^2 + 0^2}{1^2 - 0^2} = -18.7 \text{ kpsi} \quad \text{Ans.}$$

$$(\sigma_t)_o|_{\max} = p_{\max} \frac{r_o^2 + R^2}{r_o^2 - R^2} = (18.7) \frac{1.5^2 + 1^2}{1.5^2 - 1^2} = 48.6 \text{ kpsi} \quad \text{Ans.}$$

**3-120**  $d = 20 \text{ mm}$ ,  $r_i = 37.5 \text{ mm}$ ,  $r_o = 57.5 \text{ mm}$

From Table 3-4, for  $R = 10 \text{ mm}$ ,

$$r_c = 37.5 + 10 = 47.5 \text{ mm}$$

$$r_n = \frac{10^2}{2(47.5 - \sqrt{47.5^2 - 10^2})} = 46.96772 \text{ mm}$$

$$e = r_c - r_n = 47.5 - 46.96772 = 0.53228 \text{ mm}$$

$$c_i = r_n - r_i = 46.9677 - 37.5 = 9.4677 \text{ mm}$$

$$c_o = r_o - r_n = 57.5 - 46.9677 = 10.5323 \text{ mm}$$

$$A = \pi d^2 / 4 = \pi(20)^2 / 4 = 314.16 \text{ mm}^2$$

$$M = Fr_c = 4000(47.5) = 190\,000 \text{ N} \cdot \text{mm}$$

Using Eq. (3-65) for the bending stress, and combining with the axial stress,

$$\sigma_i = \frac{F}{A} + \frac{Mc_i}{Aer_i} = \frac{4000}{314.16} + \frac{190\,000(9.4677)}{314.16(0.53228)(37.5)} = 300 \text{ MPa} \quad \text{Ans.}$$

$$\sigma_o = \frac{F}{A} - \frac{Mc_o}{Aer_o} = \frac{4000}{314.16} - \frac{190\,000(10.5323)}{314.16(0.53228)(57.5)} = -195 \text{ MPa} \quad \text{Ans.}$$

---

**3-121**  $d = 0.75 \text{ in}$ ,  $r_i = 1.25 \text{ in}$ ,  $r_o = 2.0 \text{ in}$

From Table 3-4, for  $R = 0.375 \text{ in}$ ,

$$r_c = 1.25 + 0.375 = 1.625 \text{ in}$$

$$r_n = \frac{0.375^2}{2(1.625 - \sqrt{1.625^2 - 0.375^2})} = 1.60307 \text{ in}$$

$$e = r_c - r_n = 1.625 - 1.60307 = 0.02193 \text{ in}$$

$$c_i = r_n - r_i = 1.60307 - 1.25 = 0.35307 \text{ in}$$

$$c_o = r_o - r_n = 2.0 - 1.60307 = 0.39693 \text{ in}$$

$$A = \pi d^2 / 4 = \pi(0.75)^2 / 4 = 0.44179 \text{ in}^2$$

$$M = Fr_c = 750(1.625) = 1218.8 \text{ lbf} \cdot \text{in}$$

Using Eq. (3-65) for the bending stress, and combining with the axial stress,

$$\sigma_i = \frac{F}{A} + \frac{Mc_i}{Aer_i} = \frac{750}{0.44179} + \frac{1218.8(0.35307)}{0.44179(0.02193)(1.25)} = 37\,230 \text{ psi} = 37.2 \text{ kpsi} \quad \text{Ans.}$$

$$\sigma_o = \frac{F}{A} - \frac{Mc_o}{Aer_o} = \frac{750}{0.44179} - \frac{1218.8(0.39693)}{0.44179(0.02193)(2.0)} = -23\,269 \text{ psi} = -23.3 \text{ kpsi} \quad \text{Ans.}$$

---

**3-122**  $d = 6 \text{ mm}$ ,  $r_i = 10 \text{ mm}$ ,  $r_o = 16 \text{ mm}$

From Table 3-4, for  $R = 3 \text{ mm}$ ,

$$r_c = 10 + 3 = 13 \text{ mm}$$

$$r_n = \frac{3^2}{2(13 - \sqrt{13^2 - 3^2})} = 12.82456 \text{ mm}$$

$$e = r_c - r_n = 13 - 12.82456 = 0.17544 \text{ mm}$$

$$c_i = r_n - r_i = 12.82456 - 10 = 2.82456 \text{ mm}$$

$$c_o = r_o - r_n = 16 - 12.82456 = 3.17544 \text{ mm}$$

$$A = \pi d^2 / 4 = \pi(6)^2 / 4 = 28.2743 \text{ mm}^2$$

$$M = Fr_c = 300(13) = 3900 \text{ N} \cdot \text{mm}$$

Using Eq. (3-65) for the bending stress, and combining with the axial stress,



$$\sigma_i = \frac{F}{A} + \frac{Mc_i}{Aer_i} = \frac{300}{28.2743} + \frac{3900(2.82456)}{28.2743(0.17544)(10)} = 233 \text{ MPa} \quad \text{Ans.}$$

$$\sigma_o = \frac{F}{A} - \frac{Mc_o}{Aer_o} = \frac{300}{28.2743} - \frac{3900(3.17544)}{28.2743(0.17544)(16)} = -145 \text{ MPa} \quad \text{Ans.}$$

**3-123**  $d = 6 \text{ mm}$ ,  $r_i = 10 \text{ mm}$ ,  $r_o = 16 \text{ mm}$

From Table 3-4, for  $R = 3 \text{ mm}$ ,

$$r_c = 10 + 3 = 13 \text{ mm}$$

$$r_n = \frac{3^2}{2(13 - \sqrt{13^2 - 3^2})} = 12.82456 \text{ mm}$$

$$e = r_c - r_n = 13 - 12.82456 = 0.17544 \text{ mm}$$

$$c_i = r_n - r_i = 12.82456 - 10 = 2.82456 \text{ mm}$$

$$c_o = r_o - r_n = 16 - 12.82456 = 3.17544 \text{ mm}$$

$$A = \pi d^2 / 4 = \pi(6)^2 / 4 = 28.2743 \text{ mm}^2$$

The angle  $\theta$  of the line of radius centers is

$$\theta = \sin^{-1}\left(\frac{R + d/2}{R + d + R}\right) = \sin^{-1}\left(\frac{10 + 6/2}{10 + 6 + 10}\right) = 30^\circ$$

$$M = F(R + d/2)\sin\theta = 300(10 + 6/2)\sin 30^\circ = 1950 \text{ N}\cdot\text{mm}$$

Using Eq. (3-65) for the bending stress, and combining with the axial stress,

$$\sigma_i = \frac{F \sin \theta}{A} + \frac{Mc_i}{Aer_i} = \frac{300 \sin 30^\circ}{28.2743} + \frac{1950(2.82456)}{28.2743(0.17544)(10)} = 116 \text{ MPa} \quad \text{Ans.}$$

$$\sigma_o = \frac{F \sin \theta}{A} - \frac{Mc_o}{Aer_o} = \frac{300 \sin 30^\circ}{28.2743} - \frac{1950(3.17544)}{28.2743(0.17544)(16)} = -72.7 \text{ MPa} \quad \text{Ans.}$$

Note that the shear stress due to the shear force is zero at the surface.

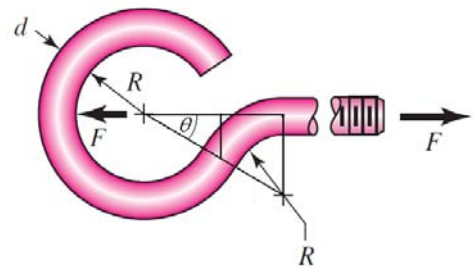

**3-124**  $d = 0.25 \text{ in}$ ,  $r_i = 0.5 \text{ in}$ ,  $r_o = 0.75 \text{ in}$

From Table 3-4, for  $R = 0.125 \text{ in}$ ,

$$r_c = 0.5 + 0.125 = 0.625 \text{ in}$$

$$r_n = \frac{0.125^2}{2(0.625 - \sqrt{0.625^2 - 0.125^2})} = 0.618686 \text{ in}$$

$$e = r_c - r_n = 0.625 - 0.618686 = 0.006314 \text{ in}$$

$$c_i = r_n - r_i = 0.618686 - 0.5 = 0.118686 \text{ in}$$

$$c_o = r_o - r_n = 0.75 - 0.618686 = 0.131314 \text{ in}$$

$$A = \pi d^2 / 4 = \pi(0.25)^2 / 4 = 0.049087 \text{ in}^2$$

$$M = Fr_c = 75(0.625) = 46.875 \text{ lbf} \cdot \text{in}$$

Using Eq. (3-65) for the bending stress, and combining with the axial stress,

$$\sigma_i = \frac{F}{A} + \frac{Mc_i}{Aer_i} = \frac{75}{0.049087} + \frac{46.875(0.118686)}{0.049087(0.006314)(0.5)} = 37\,428 \text{ psi} = 37.4 \text{ kpsi} \quad \text{Ans.}$$

$$\sigma_o = \frac{F}{A} - \frac{Mc_o}{Aer_o} = \frac{75}{0.049087} - \frac{46.875(0.131314)}{0.049087(0.006314)(0.75)} = -24\,952 \text{ psi} = -25.0 \text{ kpsi} \quad \text{Ans.}$$

**3-125**  $d = 0.25 \text{ in}$ ,  $r_i = 0.5 \text{ in}$ ,  $r_o = 0.75 \text{ in}$

From Table 3-4, for  $R = 0.125 \text{ in}$ ,

$$r_c = 0.5 + 0.125 = 0.625 \text{ in}$$

$$r_n = \frac{0.125^2}{2(0.625 - \sqrt{0.625^2 - 0.125^2})} = 0.618686 \text{ in}$$

$$e = r_c - r_n = 0.625 - 0.618686 = 0.006314 \text{ in}$$

$$c_i = r_n - r_i = 0.618686 - 0.5 = 0.118686 \text{ in}$$

$$c_o = r_o - r_n = 0.75 - 0.618686 = 0.131314 \text{ in}$$

$$A = \pi d^2 / 4 = \pi(0.25)^2 / 4 = 0.049087 \text{ in}^2$$

The angle  $\theta$  of the line of radius centers is

$$\theta = \sin^{-1} \left( \frac{R + d/2}{R + d + R} \right) = \sin^{-1} \left( \frac{0.5 + 0.25/2}{0.5 + 0.25 + 0.5} \right) = 30^\circ$$

$$M = F(R + d/2) \sin \theta = 75(0.5 + 0.25/2) \sin 30^\circ = 23.44 \text{ lbf} \cdot \text{in}$$

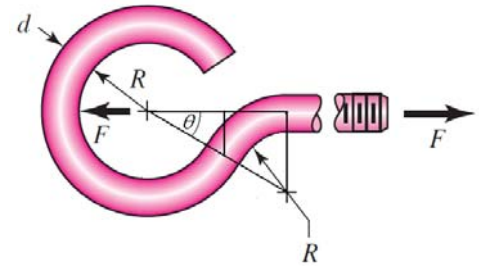

Using Eq. (3-65) for the bending stress, and combining with the axial stress,

$$\sigma_i = \frac{F \sin \theta}{A} + \frac{Mc_i}{Aer_i} = \frac{75 \sin 30^\circ}{0.049087} + \frac{23.44(0.118686)}{0.049087(0.006314)(0.5)} = 18\,716 \text{ psi} = 18.7 \text{ kpsi} \quad \text{Ans.}$$

$$\sigma_o = \frac{F \sin \theta}{A} - \frac{Mc_o}{Aer_o} = \frac{75 \sin 30^\circ}{0.049087} - \frac{23.44(0.131314)}{0.049087(0.006314)(0.75)} = -12\,478 \text{ psi} = -12.5 \text{ kpsi} \quad \text{Ans.}$$

Note that the shear stress due to the shear force is zero at the surface.

**3-126**

$$(a) \sigma = \pm \frac{Mc}{I} = \pm \frac{[3(4)][0.5(0.1094)]}{(0.75)(0.1094^3)/12} = \pm 8021 \text{ psi} = \pm 8.02 \text{ kpsi} \quad \text{Ans.}$$

$$(b) r_i = 0.125 \text{ in}, r_o = r_i + h = 0.125 + 0.1094 = 0.2344 \text{ in}$$

From Table 3-4,

$$r_c = 0.125 + (0.5)(0.1094) = 0.1797 \text{ in}$$

$$r_n = \frac{0.1094}{\ln(0.2344 / 0.125)} = 0.174006 \text{ in}$$

$$e = r_c - r_n = 0.1797 - 0.174006 = 0.005694 \text{ in}$$

$$c_i = r_n - r_i = 0.174006 - 0.125 = 0.049006 \text{ in}$$

$$c_o = r_o - r_n = 0.2344 - 0.174006 = 0.060394 \text{ in}$$

$$A = bh = 0.75(0.1094) = 0.08205 \text{ in}^2$$

$$M = -3(4) = -12 \text{ lbf} \cdot \text{in}$$

The negative sign on the bending moment is due to the sign convention shown in Fig. 3-34. Using Eq. (3-65),

$$\sigma_i = \frac{Mc_i}{Aer_i} = \frac{-12(0.049006)}{0.08205(0.005694)(0.125)} = -10\,070 \text{ psi} = -10.1 \text{ kpsi} \quad \text{Ans.}$$

$$\sigma_o = -\frac{Mc_o}{Aer_o} = -\frac{-12(0.060394)}{0.08205(0.005694)(0.2344)} = 6618 \text{ psi} = 6.62 \text{ kpsi} \quad \text{Ans.}$$

$$(c) \quad K_i = \frac{\sigma_i}{\sigma} = \frac{-10.1}{-8.02} = 1.26 \quad \text{Ans.}$$

$$K_o = \frac{\sigma_o}{\sigma} = \frac{6.62}{8.02} = 0.825 \quad \text{Ans.}$$

### 3-127

$$(a) \quad \sigma = \pm \frac{Mc}{I} = \pm \frac{[3(4)][0.5(0.1406)]}{(0.75)(0.1406^3)/12} = \pm 4856 \text{ psi} = \pm 4.86 \text{ kpsi} \quad \text{Ans.}$$

$$(b) \quad r_i = 0.125 \text{ in}, r_o = r_i + h = 0.125 + 0.1406 = 0.2656 \text{ in}$$

From Table 3-4,

$$r_c = 0.125 + (0.5)(0.1406) = 0.1953 \text{ in}$$

$$r_n = \frac{0.1406}{\ln(0.2656 / 0.125)} = 0.186552 \text{ in}$$

$$e = r_c - r_n = 0.1953 - 0.186552 = 0.008748 \text{ in}$$

$$c_i = r_n - r_i = 0.186552 - 0.125 = 0.061552 \text{ in}$$

$$c_o = r_o - r_n = 0.2656 - 0.186552 = 0.079048 \text{ in}$$

$$A = bh = 0.75(0.1406) = 0.10545 \text{ in}^2$$

$$M = -3(4) = -12 \text{ lbf} \cdot \text{in}$$

The negative sign on the bending moment is due to the sign convention shown in Fig. 3-34. Using Eq. (3-65),

$$\sigma_i = \frac{Mc_i}{Aer_i} = \frac{-12(0.061552)}{0.10545(0.008748)(0.125)} = -6406 \text{ psi} = -6.41 \text{ kpsi} \quad \text{Ans.}$$

$$\sigma_o = -\frac{Mc_o}{Aer_o} = -\frac{-12(0.079048)}{0.10545(0.008748)(0.2656)} = 3872 \text{ psi} = 3.87 \text{ kpsi} \quad \text{Ans.}$$

$$(c) \quad K_i = \frac{\sigma_i}{\sigma} = \frac{-6.41}{-4.86} = 1.32 \quad \text{Ans.}$$

$$K_o = \frac{\sigma_o}{\sigma} = \frac{3.87}{4.86} = 0.80 \quad \text{Ans.}$$

### 3-128

$$(a) \quad \sigma = \pm \frac{Mc}{I} = \pm \frac{[3(4)][0.5(0.1094)]}{(0.75)(0.1094^3)/12} = \pm 8021 \text{ psi} = \pm 8.02 \text{ kpsi} \quad \text{Ans.}$$

$$(b) \quad r_i = 0.25 \text{ in}, r_o = r_i + h = 0.25 + 0.1094 = 0.3594 \text{ in}$$

From Table 3-4,

$$r_c = 0.25 + (0.5)(0.1094) = 0.3047 \text{ in}$$

$$r_n = \frac{0.1094}{\ln(0.3594/0.25)} = 0.301398 \text{ in}$$

$$e = r_c - r_n = 0.3047 - 0.301398 = 0.003302 \text{ in}$$

$$c_i = r_n - r_i = 0.301398 - 0.25 = 0.051398 \text{ in}$$

$$c_o = r_o - r_n = 0.3594 - 0.301398 = 0.058002 \text{ in}$$

$$A = bh = 0.75(0.1094) = 0.08205 \text{ in}^2$$

$$M = -3(4) = -12 \text{ lbf} \cdot \text{in}$$

The negative sign on the bending moment is due to the sign convention shown in Fig. 3-34. Using Eq. (3-65),

$$\sigma_i = \frac{Mc_i}{Aer_i} = \frac{-12(0.051398)}{0.08205(0.003302)(0.25)} = -9106 \text{ psi} = -9.11 \text{ kpsi} \quad \text{Ans.}$$

$$\sigma_o = -\frac{Mc_o}{Aer_o} = -\frac{-12(0.058002)}{0.08205(0.003302)(0.3594)} = 7148 \text{ psi} = 7.15 \text{ kpsi} \quad \text{Ans.}$$

$$(c) \quad K_i = \frac{\sigma_i}{\sigma} = \frac{-9.11}{-8.02} = 1.14 \quad \text{Ans.}$$

$$K_o = \frac{\sigma_o}{\sigma} = \frac{7.15}{8.02} = 0.89 \quad \text{Ans.}$$

**3-129**  $r_i = 25 \text{ mm}$ ,  $r_o = r_i + h = 25 + 87 = 112 \text{ mm}$ ,  $r_c = 25 + 87/2 = 68.5 \text{ mm}$

The radius of the neutral axis is found from Eq. (3-63), given below.

$$r_n = \frac{A}{\int (dA/r)}$$

For a rectangular area with constant width  $b$ , the denominator is

$$\int_{r_i}^{r_o} \left( \frac{bdr}{r} \right) = b \ln \frac{r_o}{r_i}$$

Applying this equation over each of the four rectangular areas,

$$\int \frac{dA}{r} = 9 \left( \ln \frac{45}{25} \right) + 31 \left( \ln \frac{54.5}{45} \right) + 31 \left( \ln \frac{92}{82.5} \right) + 9 \left( \ln \frac{112}{92} \right) = 16.3769$$

$$A = 2[20(9) + 31(9.5)] = 949 \text{ mm}^2$$

$$r_n = \frac{A}{\int (dA/r)} = \frac{949}{16.3769} = 57.9475 \text{ mm}$$

$$e = r_c - r_n = 68.5 - 57.9475 = 10.5525 \text{ mm}$$

$$c_i = r_n - r_i = 57.9475 - 25 = 32.9475 \text{ mm}$$

$$c_o = r_o - r_n = 112 - 57.9475 = 54.0525 \text{ mm}$$

$$M = 150F_2 = 150(3.2) = 480 \text{ kN}\cdot\text{mm}$$

We need to find the forces transmitted through the section in order to determine the axial stress. It is not immediately obvious which plane should be used for resolving the axial versus shear directions. It is convenient to use the plane containing the reaction force at the bushing, which assumes its contribution resolves entirely into shear force. To find the angle of this plane, find the resultant of  $F_1$  and  $F_2$ .

$$F_x = F_{1x} + F_{2x} = 2.4 \cos 60^\circ + 3.2 \cos 0^\circ = 4.40 \text{ kN}$$

$$F_y = F_{1y} + F_{2y} = 2.4 \sin 60^\circ + 3.2 \sin 0^\circ = 2.08 \text{ kN}$$

$$F = (4.40^2 + 2.08^2)^{1/2} = 4.87 \text{ kN}$$

This is the pin force on the lever which acts in a direction

$$\theta = \tan^{-1} \frac{F_y}{F_x} = \tan^{-1} \frac{2.08}{4.40} = 25.3^\circ$$

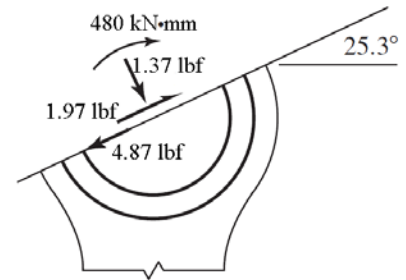

On the surface  $25.3^\circ$  from the horizontal, find the internal forces in the tangential and normal directions. Resolving  $F_1$  into components,

$$F_t = 2.4 \cos(60^\circ - 25.3^\circ) = 1.97 \text{ kN}$$

$$F_n = 2.4 \sin(60^\circ - 25.3^\circ) = 1.37 \text{ kN}$$

The transverse shear stress is zero at the inner and outer surfaces. Using Eq. (3-65) for the bending stress, and combining with the axial stress due to  $F_n$ ,

$$\sigma_i = \frac{F_n}{A} + \frac{Mc_i}{Aer_i} = \frac{1370}{949} + \frac{[(3200)(150)](32.9475)}{949(10.5525)(25)} = 64.6 \text{ MPa} \quad \text{Ans.}$$

$$\sigma_o = \frac{F_n}{A} - \frac{Mc_o}{Aer_o} = \frac{1370}{949} - \frac{[(3200)(150)](54.0525)}{949(10.5525)(112)} = -21.7 \text{ MPa} \quad \text{Ans.}$$

**3-130**  $r_i = 2 \text{ in}$ ,  $r_o = r_i + h = 2 + 4 = 6 \text{ in}$ ,  $r_c = 2 + 0.5(4) = 4 \text{ in}$

$$A = (6 - 2 - 0.75)(0.75) = 2.4375 \text{ in}^2$$

Similar to Prob. 3-129,

$$\int \frac{dA}{r} = 0.75 \ln \frac{3.625}{2} + 0.75 \ln \frac{6}{4.375} = 0.682 \text{ 920 in}$$

$$r_n = \frac{A}{\int (dA/r)} = \frac{2.4375}{0.682 \text{ 920}} = 3.56923 \text{ in}$$

$$e = r_c - r_n = 4 - 3.56923 = 0.43077 \text{ in}$$

$$c_i = r_n - r_i = 3.56923 - 2 = 1.56923 \text{ in}$$

$$c_o = r_o - r_n = 6 - 3.56923 = 2.43077 \text{ in}$$

$$M = Fr_c = 6000(4) = 24 \text{ 000 lbf} \cdot \text{in}$$

Using Eq. (3-65) for the bending stress, and combining with the axial stress,

$$\sigma_i = \frac{F}{A} + \frac{Mc_i}{Aer_i} = \frac{6000}{2.4375} + \frac{24 \text{ 000}(1.56923)}{2.4375(0.43077)(2)} = 20 \text{ 396 psi} = 20.4 \text{ kpsi} \quad \text{Ans.}$$

$$\sigma_o = \frac{F}{A} - \frac{Mc_o}{Aer_o} = \frac{6000}{2.4375} - \frac{24 \text{ 000}(2.43077)}{2.4375(0.43077)(6)} = -6 \text{ 799 psi} = -6.80 \text{ kpsi} \quad \text{Ans.}$$

**3-131**  $r_i = 12 \text{ in}$ ,  $r_o = r_i + h = 12 + 3 = 15 \text{ in}$ ,  $r_c = 12 + 3/2 = 13.5 \text{ in}$

$$I = \frac{\pi}{4} a^3 b = \frac{\pi}{4} (1.5^3)(0.75) = 1.988 \text{ in}^4$$

$$A = \pi ab = \pi(1.5)(0.75) = 3.534$$

$$M = 20(3 + 1.5) = 90 \text{ kip} \cdot \text{in}$$

Since the radius is large compared to the cross section, assume Eq. 3-67 is applicable for the bending stress. Combining the bending stress and the axial stress,

$$\sigma_i = \frac{F}{A} + \frac{Mc_i r_c}{I r_i} = \frac{20}{3.534} + \frac{90(1.5)(13.5)}{(1.988)(12)} = 82.1 \text{ kpsi} \quad \text{Ans.}$$

$$\sigma_o = \frac{F}{A} - \frac{Mc_o r_c}{I r_o} = \frac{20}{3.534} - \frac{90(1.5)(13.5)}{1.988(15)} = -55.5 \text{ kpsi} \quad \text{Ans.}$$

**3-132**  $r_i = 1.25$  in,  $r_o = r_i + h = 1.25 + 0.5 + 1 + 0.5 = 3.25$  in  
 $r_c = (r_i + r_o) / 2 = (1.25 + 3.25) / 2 = 2.25$  in *Ans.*

For outer rectangle,  $\left( \int \frac{dA}{r} \right)_{\square} = b \ln \frac{r_o}{r_i}$

For circle,  $\left[ \int \frac{A}{(dA/r)} \right]_o = \left[ \frac{r^2}{2(r_c - \sqrt{r_c^2 - r^2})} \right]_o$ ,  $A_o = \pi r^2$

$\therefore \left[ \int \frac{dA}{r} \right]_o = 2\pi(r_c - \sqrt{r_c^2 - r^2})$

Combine the integrals subtracting the circle from the rectangle

$\Sigma \int \frac{dA}{r} = 1.25 \ln \frac{3.25}{1.25} - 2\pi(2.25 - \sqrt{2.25^2 - 0.5^2}) = 0.840904$  in

$A = 1.25(2) - \pi(0.5^2) = 1.71460$  in<sup>2</sup> *Ans.*

$r_n = \frac{A}{\Sigma \int (dA/r)} = \frac{1.71460}{0.840904} = 2.0390$  in *Ans.*

$e = r_c - r_n = 2.25 - 2.0390 = 0.2110$  in *Ans.*

$c_i = r_n - r_i = 2.0390 - 1.25 = 0.7890$  in

$c_o = r_o - r_n = 3.25 - 2.0390 = 1.2110$  in

$M = 2000(4.5 + 1.25 + 0.5 + 0.5) = 13500$  lbf · in

$\sigma_i = \frac{F}{A} + \frac{Mc_i}{Aer_i} = \frac{2000}{1.7146} + \frac{13500(0.7890)}{1.7146(0.2110)(1.25)} = 20720$  psi = 20.7 kpsi *Ans.*

$\sigma_o = \frac{F}{A} - \frac{Mc_o}{Aer_o} = \frac{2000}{1.7146} - \frac{13500(1.2110)}{1.7146(0.2110)(3.25)} = -12738$  psi = -12.7 kpsi *Ans.*

**3-133** From Eq. (3-68),

$$a = KF^{1/3} = F^{1/3} \left\{ \left( \frac{3}{8} \right) \frac{2[(1-\nu^2)/E]}{2(1/d)} \right\}^{1/3}$$

Use  $\nu = 0.292$ ,  $F$  in newtons,  $E$  in N/mm<sup>2</sup> and  $d$  in mm, then

$$K = \left\{ \left( \frac{3}{8} \right) \frac{[(1-0.292^2)/207000]}{1/30} \right\}^{1/3} = 0.03685$$

From Eq. (3-69),

$$p_{\max} = \frac{3F}{2\pi a^2} = \frac{3F}{2\pi(KF^{1/3})^2} = \frac{3F^{1/3}}{2\pi K^2} = \frac{3F^{1/3}}{2\pi(0.03685)^2} = 352F^{1/3} \text{ MPa}$$

From Eq. (3-71), the maximum principal stress occurs on the surface where  $z = 0$ , and is equal to  $-p_{\max}$ .

$$\sigma_{\max} = \sigma_z = -p_{\max} = -352F^{1/3} \text{ MPa} \quad \text{Ans.}$$

From Fig. 3-37,

$$\tau_{\max} = 0.3p_{\max} = 106F^{1/3} \text{ MPa} \quad \text{Ans.}$$

**3-134** From Eq. (3-68),

$$a = \sqrt[3]{\left(\frac{3F}{8}\right) \frac{(1-\nu_1^2)/E_1 + (1-\nu_2^2)/E_2}{1/d_1 + 1/d_2}}$$

$$a = \sqrt[3]{\left(\frac{3(10)}{8}\right) \frac{(1-0.292^2)/(207\,000) + (1-0.333^2)/(71\,700)}{1/25 + 1/40}} = 0.0990 \text{ mm}$$

From Eq. (3-69),

$$p_{\max} = \frac{3F}{2\pi a^2} = \frac{3(10)}{2\pi(0.0990^2)} = 487.2 \text{ MPa}$$

From Fig. 3-37, the maximum shear stress occurs at a depth of  $z = 0.48a$ .

$$z = 0.48a = 0.48(0.0990) = 0.0475 \text{ mm} \quad \text{Ans.}$$

The principal stresses are obtained from Eqs. (3-70) and (3-71) at a depth of  $z/a = 0.48$ .

$$\sigma_1 = \sigma_2 = -487.2 \left\{ \left[ 1 - 0.48 \tan^{-1}(1/0.48) \right] (1 + 0.333) - \frac{1}{2(1 + 0.48^2)} \right\} = -101.3 \text{ MPa}$$

$$\sigma_3 = \frac{-487.2}{1 + 0.48^2} = -396.0 \text{ MPa}$$

From Eq. (3-72),

$$\tau_{\max} = \frac{\sigma_1 - \sigma_3}{2} = \frac{(-101.3) - (-396.0)}{2} = 147.4 \text{ MPa} \quad \text{Ans.}$$

Note that if a closer examination of the applicability of the depth assumption from Fig. 3-37 is desired, implementing Eqs. (3-70), (3-71), and (3-72) on a spreadsheet will allow for calculating and plotting the stresses versus the depth for specific values of  $\nu$ . For  $\nu = 0.333$  for aluminum, the maximum shear stress occurs at a depth of  $z = 0.492a$  with  $\tau_{\max} = 0.3025 p_{\max}$ .



This gives  $\tau_{\max} = 0.3025 p_{\max} = (0.3025)(487.2) = 147.38$  MPa. Even though the depth assumption was a little off, it did not have significant effect on the the maximum shear stress.

---

**3-135** From the solution to Prob. 3-134,  $a = 0.0990$  mm and  $p_{\max} = 487.2$  MPa. Assuming applicability of Fig. 3-37, the maximum shear stress occurs at a depth of  $z = 0.48 a = 0.0475$  mm. *Ans.*

The principal stresses are obtained from Eqs. (3-70) and (3-71) at a depth of  $z/a = 0.48$ .

$$\sigma_1 = \sigma_2 = -487.2 \left\{ \left[ 1 - 0.48 \tan^{-1}(1/0.48) \right] (1 + 0.292) - \frac{1}{2(1 + 0.48^2)} \right\} = -92.09 \text{ MPa}$$

$$\sigma_3 = \frac{-487.2}{1 + 0.48^2} = -396.0 \text{ MPa}$$

From Eq. (3-72),

$$\tau_{\max} = \frac{\sigma_1 - \sigma_3}{2} = \frac{(-92.09) - (-396.0)}{2} = 152.0 \text{ MPa} \quad \textit{Ans.}$$

Note that if a closer examination of the applicability of the depth assumption from Fig. 3-37 is desired, implementing Eqs. (3-70), (3-71), and (3-72) on a spreadsheet will allow for calculating and plotting the stresses versus the depth for specific values of  $\nu$ . For  $\nu = 0.292$  for steel, the maximum shear stress occurs at a depth of  $z = 0.478a$  with  $\tau_{\max} = 0.3119 p_{\max}$ .

---

**3-136** From Eq. (3-68),

$$a = \sqrt[3]{\left( \frac{3F}{8} \right) \frac{2(1-\nu^2)/E}{1/d_1 + 1/d_2}}$$

$$a = \sqrt[3]{\left( \frac{3(20)}{8} \right) \frac{2(1-0.292^2)/(207\,000)}{1/30 + 1/\infty}} = 0.1258 \text{ mm}$$

From Eq. (3-69),

$$p_{\max} = \frac{3F}{2\pi a^2} = \frac{3(20)}{2\pi(0.1258^2)} = 603.4 \text{ MPa}$$

From Fig. 3-37, the maximum shear stress occurs at a depth of  $z = 0.48a = 0.48(0.1258) = 0.0604$  mm *Ans.*

Also from Fig. 3-37, the maximum shear stress is

$$\tau_{\max} = 0.3 p_{\max} = 0.3(603.4) = 181 \text{ MPa} \quad \textit{Ans.}$$

**3-137 Aluminum Plate-Ball interface:** From Eq. (3-68),

$$a = \sqrt[3]{\left(\frac{3F}{8}\right) \frac{(1-\nu_1^2)/E_1 + (1-\nu_2^2)/E_2}{1/d_1 + 1/d_2}}$$

$$a = \sqrt[3]{\left(\frac{3F}{8}\right) \frac{(1-0.292^2)/[(30)(10^6)] + (1-0.333^2)/[(10.4)(10^6)]}{1/1 + 1/\infty}} = 3.517(10^{-3})F^{1/3} \text{ in}$$

From Eq. (3-69),

$$p_{\max} = \frac{3F}{2\pi a^2} = \frac{3F}{2\pi [3.517(10^{-3})F^{1/3}]^2} = 3.860(10^4)F^{1/3} \text{ psi}$$

By examination of Eqs. (3-70), (3-71), and (3-72), it can be seen that the only difference in the maximum shear stress for the plate and the ball will be due to poisson's ratio in Eq. (3-70). The larger poisson's ratio will create the greater maximum shear stress, so the aluminum plate will be the critical element in this interface. Applying the equations for the aluminum plate,

$$\sigma_1 = -3.86(10^4)F^{1/3} \left\{ \left[ 1 - 0.48 \tan^{-1}(1/0.48) \right] (1 + 0.333) - \frac{1}{2(1 + 0.48^2)} \right\} = -8025F^{1/3} \text{ psi}$$

$$\sigma_3 = \frac{-3.86(10^4)F^{1/3}}{1 + 0.48^2} = -3.137(10^4)F^{1/3} \text{ psi}$$

From Eq. (3-72),

$$\tau_{\max} = \frac{\sigma_1 - \sigma_3}{2} = \frac{(-8025F^{1/3}) - (-3.137(10^4)F^{1/3})}{2} = 1.167(10^4)F^{1/3} \text{ psi}$$

Comparing this stress to the allowable stress, and solving for  $F$ ,

$$F = \left[ \frac{20\,000}{1.167(10^4)} \right]^3 = 5.03 \text{ lbf}$$

**Table-Ball interface:** From Eq. (3-68),

$$a = \sqrt[3]{\left(\frac{3F}{8}\right) \frac{(1-0.292^2)/[(30)(10^6)] + (1-0.211^2)/[(14.5)(10^6)]}{1/1 + 1/\infty}} = 3.306(10^{-3})F^{1/3} \text{ in}$$

From Eq. (3-69),

$$p_{\max} = \frac{3F}{2\pi a^2} = \frac{3F}{2\pi [3.306(10^{-3})F^{1/3}]^2} = 4.369(10^4)F^{1/3} \text{ psi}$$

The steel ball has a higher poisson's ratio than the cast iron table, so it will dominate.

$$\sigma_1 = -4.369(10^4)F^{1/3} \left\{ \left[ 1 - 0.48 \tan^{-1}(1/0.48) \right] (1 + 0.292) - \frac{1}{2(1 + 0.48^2)} \right\} = -8258F^{1/3} \text{ psi}$$

$$\sigma_3 = \frac{-4.369(10^4)F^{1/3}}{1 + 0.48^2} = -3.551(10^4)F^{1/3} \text{ psi}$$

From Eq. (3-72),

$$\tau_{\max} = \frac{\sigma_1 - \sigma_3}{2} = \frac{(-8258F^{1/3}) - (-3.551(10^4)F^{1/3})}{2} = 1.363(10^4)F^{1/3} \text{ psi}$$

Comparing this stress to the allowable stress, and solving for  $F$ ,

$$F = \left[ \frac{20\,000}{1.363(10^4)} \right]^3 = 3.16 \text{ lbf}$$

The steel ball is critical, with  $F = 3.16 \text{ lbf}$ .     *Ans.*

**3-138**  $\nu_1 = 0.333$ ,  $E_1 = 10.4 \text{ Mpsi}$ ,  $l = 2 \text{ in}$ ,  $d_1 = 1.25 \text{ in}$ ,  $\nu_2 = 0.211$ ,  $E_2 = 14.5 \text{ Mpsi}$ ,  $d_2 = -12 \text{ in}$ .

With  $b = K_c F^{1/2}$

$$K_c = \left( \frac{2}{\pi(2)} \frac{(1 - 0.333^2)/[10.4(10^6)] + (1 - 0.211^2)/[14.5(10^6)]}{1/1.25 + 1/12} \right)^{1/2}$$

$$= 2.336(10^{-4})$$

By examination of Eqs. (3-75), (3-76), and (3-77), it can be seen that the only difference in the maximum shear stress for the two materials will be due to poisson's ratio in Eq. (3-75). The larger poisson's ratio will create the greater maximum shear stress, so the aluminum roller will be the critical element in this interface. Instead of applying these equations, we will assume the poisson's ratio for aluminum of 0.333 is close enough to 0.3 to make Fig. 3-39 applicable.

$$\tau_{\max} = 0.3p_{\max}$$

$$p_{\max} = \frac{4000}{0.3} = 13\,300 \text{ psi}$$

From Eq. (3-74),  $p_{\max} = 2F / (\pi b l)$ , so we have

$$p_{\max} = \frac{2F}{\pi l K_c F^{1/2}} = \frac{2F^{1/2}}{\pi l K_c}$$

So,

$$\begin{aligned} F &= \left( \frac{\pi l K_c p_{\max}}{2} \right)^2 \\ &= \left( \frac{\pi(2)(2.336)(10^{-4})(13\,300)}{2} \right)^2 \\ &= 95.3 \text{ lbf} \quad \text{Ans.} \end{aligned}$$

### 3-139

$\nu = 0.292$ ,  $E = 30$  Mpsi,  $l = 0.75$  in,  $d_1 = 2(0.47) = 0.94$  in,  $d_2 = 2(0.62) = 1.24$  in.

Eq. (3-73):

$$b = \left( \frac{2(40)}{\pi(0.75)} \frac{2(1-0.292^2) / [30(10^6)]}{1/0.94 + 1/1.24} \right)^{1/2} = 1.052(10^{-3}) \text{ in}$$

Eq. (3-74):

$$p_{\max} = \frac{2F}{\pi b l} = \frac{2(40)}{\pi(1.052)(10^{-3})(0.75)} = 32\,275 \text{ psi} = 32.3 \text{ kpsi} \quad \text{Ans.}$$

From Fig. 3-39,

$$\tau_{\max} = 0.3 p_{\max} = 0.3(32\,275) = 9682.5 \text{ psi} = 9.68 \text{ kpsi} \quad \text{Ans.}$$

### 3-140 Use Eqs. (3-73) through (3-77).

$$\begin{aligned} b &= \left( \frac{2F}{\pi l} \frac{(1-\nu_1^2)/E_1 + (1-\nu_2^2)/E_2}{(1/d_1) + (1/d_2)} \right)^{1/2} \\ &= \left( \frac{2(600)}{\pi(2)} \frac{(1-0.292^2)/(30(10^6)) + (1-0.292^2)/(30(10^6))}{1/5 + 1/\infty} \right)^{1/2} \end{aligned}$$

$$b = 0.007\,631 \text{ in}$$

$$p_{\max} = \frac{2F}{\pi b l} = \frac{2(600)}{\pi(0.007\,631)(2)} = 25\,028 \text{ psi}$$

$$\begin{aligned}\sigma_x &= -2\nu p_{\max} \left( \sqrt{1 + \frac{z^2}{b^2}} - \left| \frac{z}{b} \right| \right) = -2(0.292)(25\,028) \left( \sqrt{1 + 0.786^2} - 0.786 \right) \\ &= -7102 \text{ psi} = -7.10 \text{ kpsi} \quad \text{Ans.}\end{aligned}$$

$$\begin{aligned}\sigma_y &= -p_{\max} \left( \frac{1 + 2\frac{z^2}{b^2}}{\sqrt{1 + \frac{z^2}{b^2}}} - 2\left| \frac{z}{b} \right| \right) = -25\,028 \left( \frac{1 + 2(0.786^2)}{\sqrt{1 + (0.786^2)}} - 2(0.786) \right) \\ &= -4\,646 \text{ psi} = -4.65 \text{ kpsi} \quad \text{Ans.}\end{aligned}$$

$$\sigma_z = \frac{-p_{\max}}{\sqrt{1 + \frac{z^2}{b^2}}} = \frac{-25\,028}{\sqrt{1 + 0.786^2}} = -19\,677 \text{ psi} = -19.7 \text{ kpsi} \quad \text{Ans.}$$

$$\tau_{\max} = \frac{\sigma_y - \sigma_z}{2} = \frac{-4\,646 - (-19\,677)}{2} = 7\,516 \text{ psi} = 7.52 \text{ kpsi} \quad \text{Ans.}$$

**3-141** Use Eqs. (3-73) through (3-77).

$$\begin{aligned}b &= \left( \frac{2F(1-\nu_1^2)/E_1 + (1-\nu_2^2)/E_2}{\pi l \quad 1/d_1 + 1/d_2} \right)^{1/2} \\ &= \left( \frac{2(2000)(1-0.292^2)/[207(10^3)] + (1-0.211^2)/[100(10^3)]}{\pi(40) \quad 1/150 + 1/\infty} \right)^{1/2}\end{aligned}$$

$$b = 0.2583 \text{ mm}$$

$$p_{\max} = \frac{2F}{\pi bl} = \frac{2(2000)}{\pi(0.2583)(40)} = 123.2 \text{ MPa}$$

$$\begin{aligned}\sigma_x &= -2\nu p_{\max} \left( \sqrt{1 + \frac{z^2}{b^2}} - \left| \frac{z}{b} \right| \right) = -2(0.292)(123.2) \left( \sqrt{1 + 0.786^2} - 0.786 \right) \\ &= -35.0 \text{ MPa} \quad \text{Ans.}\end{aligned}$$

$$\begin{aligned}\sigma_y &= -p_{\max} \left( \frac{1 + 2\frac{z^2}{b^2}}{\sqrt{1 + \frac{z^2}{b^2}}} - 2\left| \frac{z}{b} \right| \right) = -123.2 \left( \frac{1 + 2(0.786^2)}{\sqrt{1 + (0.786^2)}} - 2(0.786) \right) \\ &= -22.9 \text{ MPa} \quad \text{Ans.}\end{aligned}$$

$$\sigma_z = \frac{-p_{\max}}{\sqrt{1 + \frac{z^2}{b^2}}} = \frac{-123.2}{\sqrt{1 + 0.786^2}} = -96.9 \text{ MPa} \quad \text{Ans.}$$

$$\tau_{\max} = \frac{\sigma_y - \sigma_z}{2} = \frac{-22.9 - (-96.9)}{2} = 37.0 \text{ MPa} \quad \text{Ans.}$$

**3-142 Note to the Instructor:** The first printing incorrectly had a width  $w = 1.25 \text{ mm}$  instead of  $w = 1.25 \text{ in.}$  The solution presented here reflects the correction which will be made in subsequent printings.

Use Eqs. (3-73) through (3-77).

$$b = \left( \frac{2F (1-\nu_1^2)/E_1 + (1-\nu_2^2)/E_2}{\pi l (1/d_1 + 1/d_2)} \right)^{1/2}$$

$$= \left( \frac{2(250) (1-0.211^2)/[14.5(10^6)] + (1-0.211^2)/[14.5(10^6)]}{\pi(1.25) (1/3 + 1/\infty)} \right)^{1/2}$$

$$b = 0.007 \text{ 095 in}$$

$$p_{\max} = \frac{2F}{\pi b l} = \frac{2(250)}{\pi(0.007 \text{ 095})(1.25)} = 17 \text{ 946 psi}$$

$$\sigma_x = -2\nu p_{\max} \left( \sqrt{1 + \frac{z^2}{b^2}} - \left| \frac{z}{b} \right| \right) = -2(0.211)(17 \text{ 946}) \left( \sqrt{1 + 0.786^2} - 0.786 \right)$$

$$= -3 \text{ 680 psi} = -3.68 \text{ kpsi} \quad \text{Ans.}$$

$$\sigma_y = -p_{\max} \left( \frac{1 + 2 \frac{z^2}{b^2}}{\sqrt{1 + \frac{z^2}{b^2}}} - 2 \left| \frac{z}{b} \right| \right) = -17 \text{ 946} \left( \frac{1 + 2(0.786^2)}{\sqrt{1 + (0.786^2)}} - 2(0.786) \right)$$

$$= -3 \text{ 332 psi} = -3.33 \text{ kpsi} \quad \text{Ans.}$$

$$\sigma_z = \frac{-p_{\max}}{\sqrt{1 + \frac{z^2}{b^2}}} = \frac{-17 \text{ 946}}{\sqrt{1 + 0.786^2}} = -14 \text{ 109 psi} = -14.1 \text{ kpsi} \quad \text{Ans.}$$

$$\tau_{\max} = \frac{\sigma_y - \sigma_z}{2} = \frac{-3 \text{ 332} - (-14 \text{ 109})}{2} = 5 \text{ 389 psi} = 5.39 \text{ kpsi} \quad \text{Ans.}$$